

TOWN OF DEDHAM
SEWER REGULATIONS
2006



Revised 11/17/2021

DEFINITIONS:	6
1.0 PURPOSE	11
2.0 APPLICABILITY & ADMINISTRATION	11
3.0 DRAINLAYER’S LICENSE	12
3.1 Issuance of Drainlayer Licenses	12
3.2 Application	12
3.2.1 Insurance	12
3.2.2 License Term	12
3.2.3 License Fees.....	13
3.2.4 Performance Bond	13
3.2.5 References.....	13
3.3 Notice of Violation	13
3.4 Penalties.....	14
3.5 Terminations and Suspension of License	14
3.6 License Application/Renewal Forms.....	14
3.7 Contractors working on behalf of the Town.....	14
4.0 GENERAL USE OF PUBLIC SEWERS	15
5.0 SEWER PERMITS	17
5.0.1 Permit Required.....	17
5.0.2 State Permits	17
5.0.3 Permit Types.....	18
5.0.4 Additional Requirements.....	18
5.0.5 Cost of Sewer	18
5.0.6 Unauthorized Work	18
5.0.7 Licensed Contractors (Drainlayer’s)	18
5.0.8 Sewer Permit Process	19
5.0.9 Schedule of Fees.....	19
5.0.10 Street Opening Permit	19
5.0.11 DIGSAFE and Dedham-Westwood Water District.....	19
5.0.12 Application for Local Permit.....	19
5.0.13 Eligibility.....	20
5.0.14 Expiration of Permit	20
5.0.15 Mandatory Inspection of Sewer Work.....	20
5.0.16 Video Camera Inspection	21
5.0.17 Right of Entry	21
5.1 SEWER CONNECTION PERMIT	21
5.1.1 Minimum Size, Fittings and Clean-outs	22
5.1.2 Wye Saddles	23
5.1.3 Minimum Elevations for Gravity Connection	23
5.1.4 Grease Traps.....	24
5.1.5 Industrial Connections.....	25
5.1.6 Inspection	25
5.1.7 Grinder Pumps and Sewage Ejectors.....	26

5.1.8	Testing of Service Connections	26
5.2	SEWER EXTENSION PERMIT.....	26
5.2.1	Design.....	26
5.2.2	Master Plan.....	26
5.2.3	Future Connections.....	27
5.2.4	Minimum Size	27
5.2.5	Depth	27
5.2.6	Slope.....	27
5.2.7	Minimize Solids Deposition	28
5.2.8	Slope Between Manholes	28
5.2.9	High Velocity Protection.....	28
5.2.10	Steep Slope Protection.....	28
5.2.11	Impervious Dams.....	28
5.2.12	Alignment.....	28
5.2.13	Changes in Pipe Size	28
5.2.14	Manhole Locations	28
5.3	SEWER REPAIR PERMIT.....	29
5.4	SEWER DISCONNECTION PERMIT.....	29
6.0	TECHNICAL REQUIREMENTS	30
6.1	Trench Excavation and Backfill	30
6.1.1	Traffic Control & Safety.....	30
6.1.2	Materials	30
6.2	General Construction.....	31
6.2.1	Clearing the Right of Way	31
6.2.2	Pavement Removal and Replacement.....	31
6.2.3	Blasting.....	31
6.2.4	Trench Width.....	32
6.2.5	Grade.....	32
6.2.6	Shoring, Sheet piling, and Boxing of Trenches	32
6.2.7	Location of Excavated Materials	32
6.2.8	Debris.....	32
6.2.9	Safety	32
6.2.10	Removal of Water.....	32
6.2.11	Trench Backfill Compaction.....	33
6.2.12	Excess Excavated Material	33
6.2.13	Rock Excavation	33
6.2.14	Controlled Density Fill	33
6.3	Sewer Pipe Installation	34
6.3.1	Scope.....	34
6.3.2	Materials	34
6.3.3	Joints	34
6.3.4	Preparation of Trench	34
6.3.5	Preparation of Sewer Pipe.....	35
6.3.6	Laying and Jointing Pipe and Fittings	35
6.3.7	Sewer Installation	35
6.3.8	Testing of Sewer Pipe & Appurtenances	37
6.4	Manhole and Clean-out Construction.....	37

6.4.1	Concrete	37
6.4.2	Precast Manhole Sections	37
6.4.3	Special Fittings	38
6.4.4	Drop Manholes	38
6.4.5	Manhole Frames and Covers	38
6.4.6	Watertightness	38
6.4.7	Coating.....	38
6.4.8	Manhole Steps.....	39
6.4.9	Manhole Stubs	39
6.4.10	Manhole Bench (Table)	39
6.4.11	Manhole Inverts (Flow Channel).....	39
6.4.12	Buoyancy	40
6.5	Grinder Pumps and Sewage Ejectors.....	40
6.6	Pressure Sewer Systems	41
6.6.1	Layout.....	41
6.6.2	Pipe Size	41
6.6.3	Pipe Material.....	41
6.6.4	Valves	41
6.6.5	Air Release Valves.....	41
6.6.6	Cleanout Connections	41
6.7	Wastewater Pumping Stations and Force Mains	42
6.8	Trenchless Technology.....	42
6.8.1	Existing Utilities	42
6.8.2	Pipe Jacking	42
6.8.3	Horizontal Directional Drilling.....	42
6.8.4	Boring Path Report	42
6.8.5	As-Built Trenchless Sewers.....	43
7.0	SEWER TESTING	43
7.1	Low Pressure Air Testing.....	43
7.2	Vacuum Test (Negative Air Pressure).....	44
7.3	Exfiltration Testing.....	46
7.4	Force Main Testing.....	47
7.5	Deflection Testing	47
8.0	SEWER EASEMENTS	48
8.1	Public Sewers	48
8.2	Private Sewers	49
8.3	Rules Regarding Sewer Easements	49
9.0	PROTECTION OF WATER SUPPLY	49
9.1	Cross Connections.....	49
9.2	Relation to Water Main	50
9.2.1	Horizontal Separation	50
9.2.2	Vertical Separation	50
9.2.3	Concrete Encasement.....	50
9.3	Well Areas-Zone II.....	50
9.4	Location of Sewers in Streams	50
9.4.1	Cover Depth.....	50
9.4.2	Alignment	51

10.0 VALIDITY 51
11.0 APPEALS 51
12.0 CHANGES IN THESE REGULATIONS..... 51
13.0 REGULATIONS IN FORCE..... 51

APPENDIX A – Fee Schedule
APPENDIX B – Drainlayer’s License Application and Bond Form
APPENDIX C - Sewer Flow Estimates
APPENDIX D – Sewer Details

DEFINITIONS:

Adjacent Sewer Main shall mean a public sewer main which is located: 1.) within a right of way or easement which shares a boundary line with the subject lot or estate; and 2.) the sewer main is located within that right of way or easement such that a perpendicular line projected from that sewer main will intersect a boundary line of the subject lot or estate.

Appurtenance shall mean any piece associated with the physical operation of the Dedham Sewerage System.

ASTM shall mean the material standard of the American Society for Testing and Materials.

Board of Selectman has certain policy making authority as defined by the Town of Dedham Charter.

B.O.D. (Biochemical Oxygen Command) shall mean the quantity of oxygen utilized in the biochemical oxidation of organic matter under standard laboratory procedure in five (5) days at 20°C, expressed in milligrams per liter.

Building Sewer shall mean the extension from the Building Drain to the Public Sewer System or other place of disposal, also called: building connection, house connection, house service, lateral, private sewer and service connection. Building Sewer is the preferred term. The Building Sewer is owned by the property owner up to and including its intersection with and connection to the Sanitary Sewer or Public Sewer pipe, and its maintenance, repair and replacement are the sole responsibility of the property owner.

Building Drain shall mean that part of the lowest piping of a drainage system which receives the discharge of wastewater from inside the walls of the building and extends to ten (10) feet outside the inner face of the building wall. By statute, the Building Drain comes under the jurisdiction of the plumbing inspector.

CDF (Controlled Density Fill) Also known as “Flowable Fill”. CDF is a mixture of Portland cement, flyash, sand and water. It shall contain a minimum of 250 pounds of class F flyash or high air (25%) and will be self leveling. CDF can be excavated by use of hand tools.

Cooling Water shall mean the water discharged from any system or condensation, air conditioning, cooling, refrigeration or other system of heat transfer.

Concentric shall mean the relationship between two different circular, cylindrical sewer pipes, when one is exactly centered within the other.

Contact Cooling Water shall mean water used in a process for cooling purposes that has come in direct contact with a raw material, intermediate product, waste product or finished product.

DEP shall mean the Massachusetts Department of Environmental Protection.

Director shall mean the Director of the Engineering Department of the Town of Dedham, or his authorized agent or representative.

Drain shall mean any system of pipes, catch basins, ditches, leaching facilities, or similar installations, which collect and carry storm water or rain water (See Dedham Stormwater Management By-Law, Chapter 37) and is:

- a. Located in a subdivision approved under the subdivision control Law after the adoption of these regulations.
- b. On land subject to site plan approval under Dedham Zoning By-Law.
- c. Connected directly or indirectly to the Town's drainage facilities..

Drainlayer shall mean a person or entity fully licensed, bonded, and insured to install sewers or drains in the Town of Dedham.

Drainlayer License shall mean a license required by the Town Manager for any person or entity installing a public or building sewer or drain in the Town of Dedham.

Easement shall mean an acquired legal right for the specific use of land owned by others.

Engineer shall mean any person who is licensed by the Commonwealth of Massachusetts to perform professional engineering services.

EPA shall mean the United States Environmental Protection Agency.

Garage shall mean any structure or property where one or more motor vehicles are kept, stored, or serviced, including a public or private garage, carport, motor vehicle repair shop, paint shop, service station, lubritorium, car wash, gasoline station with grease pits or wash racks or areas, or any building used for similar purposes.

Garbage – shall mean the animal and vegetable waste resulting from the handling preparation, cooking and serving of foods.

Gallons Per Day (GPD) shall mean the estimated flow of sewerage based on DEP regulations 314 CMR 7.15.

Grease, Oil and Sand Interceptors – shall mean devices used to prevent grease, oil and sand from entering the waste stream. Also known as “Grease Traps”.

Industrial Wastes shall mean the wastewater from industrial processes, trade or business as distinct from domestic (sanitary) wastes.

Infiltration shall mean the water entering a Sewerage System from the ground or a water body, including through such means as, defective building drains and sewers, pipes, pipe joints, connections, or manhole walls. Infiltration does not include, and is distinguished from inflow.

Inflow shall mean the discharge into a Sewerage System, including service connections, from such sources including, but not limited to: roof leaders, cellars, yards, and area drains, foundation drains, sump pumps, Cooling Water discharges, drains from springs, and swampy areas, manhole covers, cross connections from Storm Sewers and Combined Sewers, catch basins, storm water, surface runoff, or street wash water. Inflow does not include, and is distinguished from, infiltration.

Licensed Drainlayer shall mean a Drainlayer who has a valid and current Drainlayer License issued by the Town of Dedham.

Lot shall mean an area of land in one ownership, with definite boundaries, used, or available for use, as the site of one or more buildings.

May is permissive; **shall** is mandatory.

M.G.L. shall mean Massachusetts General Law.

MWRA shall mean Massachusetts Water Resources Authority.

Owner shall mean the person(s) holding fee simple title to a parcel, tract or lot of land, as shown by the record in the appropriate Land Registration Office, Registry of Deeds or Registry of Probate.

Natural Outlet shall mean any outlet, including Storm Sewers into a watercourse, pond, ditch, lake or other body of surface or groundwater.

Person shall mean an individual or two or more individuals, or trust, or a group, or association of individuals or any political subdivision of the Commonwealth having a common or undivided interest in a tract of land including a partnership or corporation.

pH shall mean the negative logarithm of the hydrogen ion concentration. The concentration is the weight of hydrogen ions, in grams, per liter of solution. Neutral water, for example, has a pH value of 7 and a hydrogen ion concentration of 10^{-7} .

Plans shall mean approved contract drawings, Town standards, working drawings, Detail sheets or exact reproductions thereof, which show the location, character, dimensions and details of the work to be done.

Private Sewer System shall mean a sewer system which services multiple buildings or units located on a single estate or lot. The private sewer system shall include the pipes and appurtenances, including sewer mains, necessary to connect multiple buildings located on a single lot or estate to an adjacent public sewer main. Sewers installed in Private Ways serving multiple distinct lots **are not** considered as Private Sewer Systems.

Private Sewerage Disposal System shall mean a privately owned and operated sewerage disposal system covered by the State's Title V Regulations (310 CMR 15.00).

Private Way shall mean a privately owned way open for or dedicated to use or travel by members of the general public in accordance with Massachusetts General Laws Chapter 41 section 77.

Properly Shredded Garbage shall mean the wastes from the preparation, cooking and dispensing of food that have been shredded to such a degree that all particles will be carried freely under the flow conditions normally prevailing in public sewers, with no particle greater than ½ inch in any dimension.

Public Sewer System shall mean a common sewer or any sewer controlled by a governmental agency or public entity. The Public Sewer System does not include connections to or any other portions of any Building Sewer. All sewers or drains laid in any land or way, public or private, opened or proposed to be opened for public travel shall be considered a common sewer.

Public Way shall mean a way open for travel owned in fee or easement by the Town of Dedham or other public entity.

Recorded shall mean recorded in the Registry of Deeds of Norfolk County, except that, as affecting registered land, it shall mean filed with the Recorder of The Land Court. (Section 81-L of Chapter 41, M.G.L.).

Right-of-Way shall mean the area that has been laid out for travel purposes.

Sanitary Sewer shall mean a Sewer that carries Sanitary Sewage and/or Industrial Wastes.

Septage shall mean the wastes from holding tanks such as chemical toilets, campers or trailers, and wastes from septic tanks and cesspools.

Sewage shall mean the spent water of a community, which may be a combination of liquid and water-carried Wastes from residences, commercial buildings, industrial facilities, and institutions, together with any groundwater, surface water, and/or storm water that may be present.

Sewer shall mean a pipe or conduit that carries Sewage.

Sewer System shall mean pipelines or conduits, pumping stations, force mains, and all other structures, devices, appurtenances, and facilities used for collecting and conveying wastes to a site or works for treatment or disposal.

Sewer Connection shall mean the sewer pipes and Appurtenant works necessary to connect a building or estate to an Adjacent Public Sewer Main.

Sewer Extension shall mean the addition to a Sewer System of a sewer pipe, together with Appurtenant works, which when connected to the sewer system becomes a sewer main and is the property of, and operated and maintained by, the person owning the sewer system.

Sewer Use Discharge Permit shall mean the permit required or issued jointly by MWRA and a Municipality for the discharge of industrial waste.

Shall is mandatory; **may** is permissive.

Slope shall mean the inclination of a trench bottom or a trench sidewall, expressed as a ratio of vertical distance to the horizontal distance. For example, a 3:1 slope shall rise or fall 3 vertical feet in a distance of 1 horizontal foot.

Solid Waste shall mean any unwanted or discarded solid material, consisting of putrescible or nonputrescible solid waste material, including garbage and rubbish.

Storm Drain or Storm Sewer shall mean a pipe or conduit for conveying ground, storm, or surface waters, roof and surface runoff, uncontaminated Cooling Water, and non-contact industrial process waters.

Subgrade shall mean the plane at the bottom of the sub-base.

Surveyor shall mean a person who is registered by the Commonwealth of Massachusetts to perform professional land surveying services.

Town – shall mean the Town of Dedham, Massachusetts or any duly authorized officer, agent or representative of the Town of Dedham.

Town Manager Shall mean the Town Manager for the Town of Dedham, or his authorized agent or representative.

Unpolluted Water – is the water of quality equal to or better than the treated effluent criteria in effect or water that would not cause violation of receiving water quality standards and would not be benefited by discharge to the sewers and wastewater treatment facilities provided.

Users – shall include all persons connected to the Town of Dedham Sewer System.

Wastewater shall mean the used water of a community. From the standpoint of source, it may be a combination of the liquid and water-carried wastes from residences, commercial buildings, industrial plants, and institutions together with any groundwater, surface water and stormwater that are not admitted intentionally.

Wastewater Facility shall mean the structures, equipment and processes required to collect, transport and treat domestic and industrial wastes and dispose of the effluent.

Watercourse shall mean a natural or artificial channel for the passage of water either continuously or intermittently.

1.0 Purpose

These regulations are intended to protect the public health, safety and welfare and the environment and to ensure proper and safe operation of the Dedham Municipal Sewer System by regulating the direct and indirect discharge of wastewater and pollutants to the Sewerage System in accordance with 360 CMR 10.000.

In the absence of code provisions or in amplification thereof, the materials and procedures as set forth in appropriate specifications shall apply:

- ❑ American Society of Testing Material (ASTM), and the Water Pollution Control Federation (WPCF) Manual of Practice No.7, "Operation and Maintenance of Wastewater Collection Systems".
- ❑ American Society of Civil Engineers (ASCE), Manuals and Reports in Engineering Practice No.60, "Gravity Sanitary Sewer Design and Construction".
- ❑ New England Interstate Water Pollution Control Commission Technical Report #16 (TR-16), "Guides for the Design of Wastewater Treatment Works".
- ❑ Current Town of Dedham, Department of Public Works, "Design and Construction Standards"

The Director shall, in the case of any discrepancies or questions, direct the Contractor accordingly.

2.0 Applicability & Administration

- 2.1 The Town Manager shall have and exercise all powers vested in the Town by the Massachusetts General Laws or special acts pertaining to the sewer systems. The Town Manager has designated the Director to accomplish the administration of these regulations in relation to the Dedham Municipal Sewer System. As designated by the Town Manager, the Department of Public Works shall carry out the day to day operation and maintenance of the sanitary sewer system
- 2.2 The Town Manager, with the assistance of the Director, shall establish, amend and promulgate local limits and regulations consist with MWRA regulations and guidelines for the Town's sewer connections to the MWRA Sewerage System.
- 2.3 The operation and maintenance of the public sewers shall be performed by the Department of Public Works in accordance with the rules and regulations of the Town of Dedham and the MWRA including, but not limited to, the requirements of 360 CMR 10.000.
- 2.4 The Town Manager requires all contractors in the business of installing sewer and drains to be licensed with the Town. The Town Manager has designated Board of Selectmen to be the licensing authority and to administer the licensing program as described by these regulations.
- 2.5 No unauthorized person shall uncover, make any connections with or opening into, use, alter, or disturb any public or private sewer appurtenance thereof without first obtaining approval of a Sewer Permit for the connection, extension, repair, or disconnection of a sewer as appropriate from the Director.

- 2.6 Every person who directly or indirectly discharges Wastewater to the Town of Dedham Sewerage System shall ensure that such discharge complies with 360 CMR 10.00. The requirements of 360 CMR 10.00 applies to direct discharges to the Dedham Sewerage System and to discharges to the Dedham Sewerage System through a municipal sewer.

3.0 Drainlayer's License

3.1 Issuance of Drainlayer Licenses

Any Drainlayer working on land in the Town of Dedham shall be licensed pursuant to these regulations. License applications shall be obtained from the Board of Selectmen through the Director or his designee at the Town of Dedham, Engineering Department, Fifty-five River Street, Dedham, Massachusetts, 02026, telephone number (781) 751-9350. The license shall be in the name of the entity or an individual. A Drainlayer license application is attached in Appendix B.

3.2 Application

A license application shall not be considered complete unless a valid State of Massachusetts Heavy Equipment Operators License, Certificate(s) of Insurance, Performance Bond, references, and the appropriate fee accompany it. The entity or individual shall complete the license application and submit it to the Director, who will present the completed application to the Board of Selectmen for approval within twenty-one (21) days. The Town shall maintain an up-to-date list of Licensed Drainlayer's, which shall be provided to residents and others requesting the same.

3.2.1 Insurance

The licensed Drainlayer shall file an insurance certificate(s) listing the Town as additionally insured and stating that the Town shall be notified thirty (30) days prior to cancellation annually with the Town of Dedham for the appropriate insurance coverage shown below:

- a. Worker's Compensation Insurance for the protection of all employees in accordance with applicable state law.
- b. Contractor's Liability with limits of \$1,000,000.00.
- c. Automotive liability on and off public highways, owned vehicles, hired vehicles, and non-ownership liability with a limit of \$1,000,000.00.

Liability insurance shall cover property damage insurance, blasting and explosion, underground damage to utilities, and collapse, and be issued by an insurance agency licensed to do business in Massachusetts.

3.2.2 License Term

The license term for a Drainlayer shall be January 1st to December 31st.

3.2.3 License Fees

Licensed Drainlayers shall pay an annual license fee of \$250.00 to the Town of Dedham at the time of application or renewal. All licenses regardless of the date of application date shall expire on December 31st of that year.

3.2.4 Performance Bond

A performance bond in the sum of \$5,000 that shall remain in full effect for a period of two (2) years from the effective date of the license and shall be required each year of licensure. The performance bond shall be prepared on the attached form included in Appendix B of these regulations.

Upon renewal of a license or in subsequent years application the Drainlayer shall either submit a new bond which shall remain in full force for a period of two (2) years from the date of application or renewal, or extend the length of the current bond on file, by means of a certificate of rider so that the expiration date of the current bond will be changed to be in full effect for a period of two (2) years from the date of application or renewal.

3.2.5 References

The Drainlayer shall submit a list of at least three references that are familiar with the past work and experience of the Drainlayer. The list shall include the name, organization, contact number(s), and brief description of the type of work performed for each reference. Other municipal references are preferred.

3.3 Notice of Violation

The Town will issue a "Notice of Violation" whenever it determines that:

1. A contractor is performing work without proper licensure.
2. A contractor is in non-compliance with the Rules and Regulations set forth by the Department of Public Safety.
3. Construction is proceeding in a manner that jeopardizes public safety.
4. Construction is occurring in violation of these Standards and/or any other applicable approved specification or detail.
5. Sewer construction is proceeding without a valid permit.
6. There is a connection of any source of clear water (inflow and/or infiltration) to the Building Sewer.
7. There is, or has been, a discharge, into the Town of Dedham Sewerage System, of any prohibited water or wastes as defined in 360 CMR 10.000.
8. Work is taking place in the right-of-way without proper permits and/or notifications.
9. There is damage to the roadway, public property, or utilities resulting from the work.
10. There are debris and/or soils in the roadway resulting from the work.
11. Work is not completed, including necessary testing and as-built documentation.

Any person found to be violating any provision of these Regulations shall be served by the Town with written notice stating the nature of the violation and provided with a reasonable time limit for the satisfactory correction thereof. The offender shall, within the period of time stated in such notice, permanently cease and correct all violations.

The Town Manager has designated the Director to enforce these regulations.

3.4 Penalties

The Director may impose a **\$250.00** fine in accordance with Chapter 15, Section 3 of the General By-Laws of the Town against any Drainlayer who violates the requirements contained herein until the violation is rectified and accepted by the Director. The licensed Drainlayer may appeal the fine to the Board of Selectmen. The appeal must be made in writing within 10 business days of issuance.

In addition, and not in lieu of a fine, any person(s) violating any of the provisions of these Regulations shall be subject to a civil penalty up to \$5,000.00 for each violation, as provided by M.G.L. Chapter 83, Section 10. Each day a violation shall continue shall be deemed a separate offense.

Any person violating any of the provisions of these Regulations shall become liable to the Town for any expense, loss or damage incurred by the Town by reason of such violations.

3.5 Terminations and Suspension of License

The Board of Selectmen may terminate or suspend any Drainlayer license upon due notice and after a public hearing for violating any of the specifications contained herein including the expiration of bonds and/or insurance. There shall not be any rebate on the annual fee upon termination. Termination will be for just cause including shoddy workmanship, performing work without a permit, excessive groundwater infiltration to sewers, deliberate groundwater infiltration, incomplete work, any violation of this regulation, not completing proper as-built plans, gravel or stones or soil entering the sewer, septage in flow, and other just causes. The contractor may apply for reinstatement, but the Town retains the right to not reissue the license or only reissue it in the future at its discretion.

3.6 License Application/Renewal Forms

The Application for Drainlayer's License can be found in Appendix B of these regulations. The Director may issue a negative recommendation to the Board of Selectmen based on previous violations, negative references, or lack of relevant experience. Also, the Town of Dedham may withhold approval of any licenses and/or permits for outstanding taxes or fees.

3.7 Contractors working on behalf of the Town

Any contractor performing construction or repair of sewers and drains as part of a contract with the Town of Dedham who is working on behalf of the Engineering Department or Public Works Department shall be exempt from the requirements of this section, provided that the contractor maintains insurance and bonding requirement equal to or greater to the

requirements of these regulations. Contractors under contract with the Town must be licensed if they wish to perform other work not associated with a Town Contract.

4.0 General Use of Public Sewers

- 4.1** It shall be unlawful to discharge within the Town of Dedham any polluted water without the applicable town, state and federal discharge permits.
- 4.2** Except as hereinafter provided, it shall be unlawful for property owners to construct or repair any privy, privy vault, septic tank, cesspool or other facility intended or used for the disposal of wastewater where the public sewer is within three hundred (300) feet of the property line and where permission to enter such sewer can be obtained from the authority having jurisdiction over it.
- 4.3** A separate and independent building sewer shall be provided for every building and every independently owned unit except where there is an existing and legally enforceable maintenance agreement between the owners of the units and the owner of the property.
- 4.4** Existing (old) building sewers shall not be used to serve a new building and or a building that is substantially remodeled (in excess of 50% of the existing building value) unless it can be demonstrated that the material, condition, construction, and useful life of the existing sewer is adequate and would be comparable to a new sewer. New building sewers shall be installed as follows and as described in these Regulations.
- 4.5** The following discharges are prohibited:
- 4.5.1** No person(s) shall discharge or cause to be discharged any unpolluted waters such as stormwater, surface water, groundwater, roof or surface runoff, tidewater, subsurface drainage, uncontaminated cooling water, unpolluted industrial process waters, non-contact cooling water, or non-contact industrial process waters to any public sanitary sewer. In general, only sanitary sewage shall be discharged to the common sewer.
- 4.5.2** No person shall discharge or cause to be discharged substances, materials, waters, or wastes if it appears likely, in the opinion of the Director, that such wastes can harm either the sewers, sewage treatment process, or equipment, have an adverse effect on the receiving stream, or can otherwise endanger life, limb, public property, or constitute a nuisance.
- 4.5.3** Unless otherwise stated herein the provisions of 360 CMR 10 shall govern all discharges to the sanitary sewer system.
- 4.5.4** Any Storm Sewer discharge shall be governed by Dedham Stormwater Management Bylaw Chapter 37, and the regulations promulgated thereunder.
- 4.6** No person(s) shall make connection of roof downspouts, foundation drains, sump pumps, area drains or other sources of surface runoff or groundwater to a building sewer or building drain, which in turn, is connected directly or indirectly to the public sewer. The Director or

his representative reserves the right to inspect any property to confirm that there are none of the aforementioned unauthorized connections to the public sewer.

- 4.7** No person(s) shall maliciously, willfully or negligently break, damage, destroy, uncover, deface or tamper with the structures, mains or other appurtenances or equipment which is part of the sewerage system or wastewater facilities or public storm drain. Any person(s) violating this provision shall be subject to all civil or criminal penalties as provided by M.G.L. or these Regulations.
- 4.8** The maintenance and cleaning of building sewers and building drains (see "Definitions" section of the Sewer Use Regulation) shall be the responsibility of the owner of the house or estate benefited by such building sewer.
- 4.9** The Director, Director of Public Works, and other duly authorized employees or agents of the Town bearing proper credentials and identification shall be permitted to enter, at reasonable times, all private properties connected with public sewers for the purposes of inspection, observation, measurement, sampling, and testing pertinent to discharge to the wastewater facilities in accordance with the provisions of these regulations.
- 4.9.1** The Director may, at his discretion, require the connection and building sewer and all parts thereof to be inspected using closed circuit television equipment. Video camera inspections may be performed to inspect for, but not limited to, the following:
- a. Joint separation.
 - b. Pipe sags.
 - c. Construction debris in sewer line.
 - d. Properly installed joints.
 - e. Deformed pipes.
 - f. Cracks in pipes.
 - g. Inflow and/or Infiltration.
 - h. Number of fittings and distance between manholes.
 - i. Illegal discharge of clear water.

Video camera inspections shall be completed in accordance with the current edition of NASSCO (National Association of Sewer Service Companies) Specifications.

- 4.9.2** Should an in-person or video inspection reveal the presence of any condition set forth in Section 4.9.1 that is causing or may cause infiltration of clean water into the System, be the source of infiltration shall be removed following the Town's Sewer Regulation for Removal of Sources of Infiltration, where applicable. A copy of this regulation can be found on the Town's website at the following URL

<https://www.dedham-ma.gov/departments/engineering/private-infiltration-removal-policy>

- 4.9.3** Notwithstanding anything in the Town's Sewer Regulation for Removal of Sources of Infiltration, all sources of infiltration & inflow in private sewer lines shall be removed when the property owner is ordered to do so by the Director.

- 4.10** The Director or other duly authorized employees or agents are authorized to obtain information concerning industrial processes which have a direct bearing on the kind and source of discharge to the wastewater facilities. The industry may withhold information considered confidential. However, the industry must establish that disclosure of the information in question to the public might result in an advantage to competitors.
- 4.11** Where a public sewer is not available, the building sewer shall be connected to a private wastewater disposal system complying with the requirements of the Board of Health of the Town of Dedham acting under the provisions of Title 5 of the "State Environmental Code for the Commonwealth of Massachusetts, Minimum Requirements for the Subsurface Disposal of Sanitary Sewage", 310 CMR 15, or regulations relative thereto, and/or the Massachusetts Department of Environmental Protection (DEP).
- 4.12** Connections to the sewer system shall conform to the following:
- 4.12.1** No person(s) shall uncover (excavate), connect, or cause to be connected to, or make any opening into, use, alter, or disturb any building sewer, public sewer, or appurtenances thereof except by written permit from the Director. The permit shall be obtained in accordance with these regulations. Any person proposing a new discharge into the public sewer, a substantial change in the volume or character of pollutants that are being discharged into the public sewer, or new sewer extension shall submit plans and calculations for the connection or extension, stamped by a Massachusetts Registered Professional Engineer in compliance with 250 CMR 4.00, in accordance with these regulations. A permit must also be obtained for any repair work to existing building or common sewers, or for any disconnection of an existing sewer.
- 4.12.2** One building sewer will not be allowed to connect and serve more than one house or dwelling unit under separate ownership except in the case of condominiums.
- 4.12.3** No contractor, person(s), entity or corporation shall be issued a permit or be otherwise allowed to connect, extend, repair or disconnect any sewer or appurtenance unless they possess a current and valid Drainlayer's License issued by the Town of Dedham in accordance with the current Sewer Regulations.

5.0 Sewer Permits

5.0.1 Permit Required

No person shall connect to a Municipal Sewer System, or construct, effect, modify, or maintain a sewer extension, connection, repair, or disconnection without a sewer permit issued by the Director, and when required a DEP industrial sewer use permit pursuant to M.G.L. c.21§ 43, 314 CMR 7.00 and 360 CMR 10.000.

5.0.2 State Permits

All industrial sewer users requiring a DEP Permit shall have a plan and necessary calculations prepared by a Registered Professional Engineer in the Commonwealth of Massachusetts. The Department of Environmental Protection (DEP) must approve the

Industrial Sewer Use Permit before the Town will issue any Sewer Connection, Extension, or related Street Opening Permits.

5.0.3 Permit Types

The Town of Dedham Engineering Department must issue a Sewer Permit for all repairs, modifications, disconnections, connections, or extensions to the Dedham Sewer System. In addition, Sewer Permits are required for the expansion of any existing building connected to the system that requires alteration or retrofit of the existing sewer or any of its direct appurtenances.

5.0.4 Additional Requirements

Installation of Sewers and Drains shall be in accordance with these regulations and standards, the current Town of Dedham, Department of Public Works, "Design and Construction Standards" as well as any requirements of the Director. The Town of Dedham reserves the right to waive any specification or to impose other regulations as required based on field conditions. Details of various Sewer components are attached in Appendix D and made a part of these regulations and standards.

5.0.5 Cost of Sewer

All costs and expense(s) incident to the installation and connection of the building sewer, including the construction or reconstruction of a common sewer if necessary, shall be borne by the owner. The owner shall indemnify the Town from any loss or damage that may directly or indirectly be occasioned by the installation of the building sewer.

5.0.6 Unauthorized Work

No unauthorized person shall maliciously, willfully or negligently break, damage, destroy, uncover, deface or tamper with any structure, appurtenance or equipment that is a part of the sewerage works. Any person violating this provision shall be subject to immediate arrest under the charge of disorderly conduct.

5.0.7 Licensed Contractors (Drainlayer's)

Only contractors licensed by the Town of Dedham will be permitted to construct or repair Sewers. Any Sewer installed by contractors not licensed by the Town will be rejected. A list of Licensed Drainlayers may be obtained at the Dedham Engineering Department. **Licensed Drainlayers shall not sub-contract Sewer installation work to anyone other than a Town licensed Drainlayer.** If the Licensed Drainlayer of record no longer intends to perform the work the permit will become null and void unless transferred in writing prior to commencing the work to another Drainlayer who is currently licensed under these regulations. Failure to comply with this provision shall lead to a Notice of Violation for the Licensed Drainlayer and may result in loss of such License.

5.0.8 Sewer Permit Process

Prior to beginning any work on any sewer in the Town of Dedham, a licensed Drainlayer shall obtain the appropriate permits as listed below:

- ❑ Sewer connections for new or existing buildings made to the Town's Sanitary Sewer System:
A Dedham Sewer Connection Permit issued by the Director
- ❑ Sewer main extensions (Including sewer to be installed on private roads) require:
A Dedham Sewer Extension Permit issued by the Director.
- ❑ Industrial Sewer Connections require both:
A Sewer Use Discharge Permit issued by MWRA; and
A Dedham Sewer Connection Permit issued by the Director
- ❑ Sewer repairs require a Dedham Sewer Repair Permit issued by the Director.
- ❑ Sewer Disconnections (cut and cap) require a Sewer Disconnection Permit issued by the Director.

5.0.9 Schedule of Fees

A schedule of fees is located in Appendix A.

5.0.10 Street Opening Permit

A Drainlayer shall obtain a Street Opening Permit from the Department of Public Works, and obtain a police detail when necessary as determined by the Chief of Police, if construction of the sewer requires construction in a traveled way of a street or work within the Right of Way.

5.0.11 DIGSAFE and Dedham-Westwood Water District

Prior to beginning any excavation of a sewer or drain, the licensed Drainlayer shall contact DIGSAFE at telephone number 1-888-DIG-SAFE to have all underground utilities located. The licensed Drainlayer shall also notify the Dedham-Westwood Water District (781) 329-7090 at least three (3) business days before construction is to begin so that the Dedham-Westwood Water District can mark the water lines at the site.

5.0.12 Application for Local Permit

The owner(s) and Drainlayer shall complete a Dedham Sewer Permit application in writing and submit the application to the Director. In addition, the applicant may be required to obtain other state or federal permits, as described in section 5.0.8, prior to issuance of a local sewer permit. The permit application shall be supplemented by a completed set of design plans, including but not limited to existing conditions, proposed grading and drainage, proposed site layout, proposed sewer profile, details and other information considered pertinent in the judgment of the Director. The permit fees, described in Appendix A, shall be paid to the Town at the time the application is filed. The application

fee is **non-refundable**. Applications for sewer permits signed by the licensed Drainlayer must be made at the office of the Director.

The Director may require an evaluation of a proposed sewer connection be performed by a Massachusetts Registered Professional Engineer, to assess the impact of additional flow on the public sewer. The cost of said evaluation shall be borne by the applicant. A permit application may be denied if the additional flow is determined to have an adverse effect on the public sewer adjacent to and downstream of the proposed connection.

5.0.13 Eligibility

The Town of Dedham shall only issue permits to contractors licensed to perform work as Drainlayer's in the Town of Dedham.

NOTE: The Town of Dedham may deny permits to any applicant who has previously violated, or is currently in violation of, these Standards or any other Dedham rules, regulations, standards, specifications or details described herein. In addition the Town of Dedham may deny permits to any Drainlayer who has not satisfactorily completed or furnished required testing reports or as-builts for previous permits.

5.0.14 Expiration of Permit

- A. The Permit will expire if the work is not initiated within one year (365 days) from the date of issuance. Upon Permit expiration, a new Permit, including payment of the Permit fee, will be required for the future connection and inspection(s).
- B. A sewer permit will become void if request to cancel the permit is received by either the owner or Drainlayer who originally applied for the permit. No refunds will be issued for canceled or duplicate permits. No permit shall be transferred to a different Drainlayer unless permission to transfer is granted in writing by the original Drainlayer on a permit.
- C. The Town of Dedham may extend the duration of the Permit for a reasonable period. Requests for extension of the Permit period must be submitted in writing to the Dedham Engineering Department in advance of the expiration and must state the reason for request.

5.0.15 Mandatory Inspection of Sewer Work

- A. The Contractor shall notify the Engineering Department prior to beginning any work and again (if necessary) when that sewer work is available for inspection. Notification is to be provided at least twenty-four (24) hours before the inspection is desired. The Engineering Department will perform inspections on sewers during normal Engineering Department business hours, or as agreed to in advance with the Engineering Department. No holiday, weekend, or off-hours work shall be allowed except by permission of the Engineering Department.
- B. It is the responsibility of the Contractor to ensure that the sewer is inspected, in its entirety, and that all work is exposed for inspection and constructed in accordance with

these standards. Under no circumstance shall the Sewer work be backfilled without an inspection by the Director or his authorized representative.

- C. The Director may require re-excavation of a buried sewer utility if an inspection was not performed at the time of installation.

5.0.16 Video Camera Inspection

The Director may, at his discretion, require the connection to be inspected using closed circuit television equipment. Video camera inspections shall be performed to inspect for, but not limited to, the following:

- j. Joint separation.
- k. Pipe sags.
- l. Construction debris in sewer line.
- m. Properly installed joints.
- n. Deformed pipes.
- o. Cracks in pipes.
- p. Inflow and/or Infiltration.
- q. Number of fittings and distance between manholes.
- r. Illegal discharge of clear water.

Video camera inspections shall be completed in accordance with the current edition of NASSCO (National Association of Sewer Service Companies) Specifications. If the sewer was not installed correctly, in the sole opinion of the Director, it shall be excavated and re-installed at the expense of the Owner.

5.0.17 Right of Entry

An authorized representative of the Town of Dedham shall have the right of entry to, upon or through the Owner's Premises for purposes of inspecting Building Sewers or to determine if any sources of clear water are connected to the Building Sewer.

5.1 Sewer Connection Permit

A Dedham Sewer Connection Permit must be issued before the installation of any service connection. A sewer connection will only be allowed when there is an existing suitable common sewer main in a way as it abuts the lot or estate to be connected. As necessary, property owners seeking a connection to the Public Sewer may provide for the extension of the Public Sewer to their property at their sole effort and expense and in accordance with these Regulations and such other reasonable requirements as the Town may make. For connections to new or existing buildings, a plan and profile of the sewer connection is to be completed by a Massachusetts Registered Professional Engineer and is to be submitted with the sewer permit application. The plan and profile of the sewer shall show the proposed sewer including all bends, clean-outs, and manholes, along with the proposed building and all other utilities. In addition, sewer connections to existing sewer mains shall utilize to the maximum extent possible existing wyes or laterals when available. The Town will make available all information in the form of plans or television inspection logs to determine if a wye or lateral exists to a specific lot or lots. In the absence of records the Town may require that the applicant perform a internal television inspection of the sewer line to determine if and where wyes or laterals exist prior to issuance of a permit.

5.1.1 Minimum Size, Fittings and Clean-outs

- A. Building Sewers must be a minimum of six (6) inches in diameter and sized based on the anticipated flows. Building Sewers must have a tee-wye clean-out located (10) feet from the buildings exterior wall.
- C. Sewer Service is to begin a maximum of ten (10) feet off the inside wall of building foundation.
- D. Six (6) inch pipe must be used to within ten (10) feet of the building, at which point the plumbing regulations will be adhered to. If a four (4) inch pipe extends from the building, a four (4) to six (6) inch Fernco Flexible Coupling (or approved equal) will be used in joining the six (6) inch to the four (4) inch pipe. A licensed plumber must perform all work within ten (10) feet of the building.
- E. All changes in direction are to be made with either twenty-two and a half (22½) or forty-five (45) degree bends with at least three (3) feet of horizontal pipe between fittings. At a minimum, where two bends are used to form a ninety (90) degree turn, a tee-wye clean-out shall be provided. A clean-out shall be provided every one hundred (100) feet. Where conditions warrant, as determined by the Director, a sewer manhole shall be provided in lieu of a clean-out.
- F. All clean-outs must be the same diameter as the horizontal Building Sewer into which the clean-out is connected; minimum of six (6) inches.
- G. All clean-outs must be extended to within six (6) inches of finished grade and be provided with a screw on cap. A steel strap or piece of rebar shall be placed on or against the vertical section of pipe to aid in future recovery with a metal detector.
- H. If a cleanout is installed under a paved or traveled area, an appropriate size frame and cover shall be provided and brought to grade with courses of barrel block, brick, and mortar. The frame and cover shall be installed as to prevent any load from being transferred onto the PVC riser or screw plug.
- I. Crushed stone shall be placed a minimum of six (6) inches above and below and all around the Sewer pipe at full width of the trench and around any cleanouts.
- J. Slope requirements within the building must conform to the latest edition of the State of Massachusetts Plumbing Code, local codes, and to these standards, whichever is more stringent.
- K. Building Sewers must be installed at a minimum slope of 2.00% (1/4" per foot) and a maximum slope of 7.00%. The Town, depending on site conditions, may modify the slope requirements.

- L. Sewers must not connect directly into any manhole without the prior written approval of the Director. Inside drop connections to manholes are not permitted, unless prior approval of the Director is granted.
- M. Building Sewers must maintain a minimum cover (from finished grade to top of pipe) of three (3) feet. The Town will not accept Sewers installed with less than three (3) feet of cover in a right-of-way or easement, unless prior permission has been obtained from the Director.
- N. A separate and independent building sewer shall be provided for every building. However, where one building stands at the rear of another on an interior lot, both buildings are located in Dedham, and no private sewer is available or can be constructed to the rear of the building through an adjoining alley, court, yard, or driveway, the building sewer from the front building may be extended to the rear building and the whole considered as one building sewer. If in the case of a residential accessory structure, an existing separate lateral or tee is to be used if available. If no available lateral or tee exists, the accessory structure may be connected by a wye into the existing house service provided that the entire service is upgraded to PVC.
- O. All commercial, industrial, and residential apartment and condominium buildings with 4 or more units shall use a sewer manhole, in place of a clean-outs, outside of the building foundation and for changes in direction.

5.1.2 Wye Saddles

- A. Where a lateral or tee does not service a property, a wye saddle may be used on the sewer main with approval of the Director.
- B. A Fernco-type wye saddle may be used under the following conditions. A hole shall be carefully cored at the 10-12 o'clock position on the pipe, making sure not to damage the sewer main in any way. The saddle is then strapped securely around the main with steel strapping and concrete is poured completely around the saddle.
- C. No saddle connections to the sewer will be allowed in new subdivision construction or on existing PVC sewer mains. Only rigid slip couplings shall be allowed on PVC sewer mains.

5.1.3 Minimum Elevations for Gravity Connection

- A. Upon exiting the building, the Sewer must maintain a minimum cover (from finished grade to top of pipe) of three (3) feet. Where an existing sewer pipe exits an existing building with less than three (3) feet of cover, the contractor shall install the connection so as to meet minimum cover requirements as soon as is practical.
- B. In cases where the building sewer crosses a water main or service with less than eighteen (18) inches of vertical separation between the pipes, the Contractor shall completely encase the joints of the sewer pipe with six (6) inches of 3,000 PSI concrete using a form (not free flow). Any joint in the sewer pipe which falls within ten (10) feet measured horizontally from the centerline of the water main or service

shall be encased. This encasement must be inspected by the Engineering Department prior to backfill. Based on existing or anticipated field conditions, the Engineering Department may require additional concrete encasement.

5.1.4 Grease Traps

- A. All restaurant and food service establishments, as defined in 105 CMR 590.001 or any successor regulation, shall be equipped with an exterior grease trap which complies with the construction and maintenance specifications set forth in Title V of the State Environmental Code 310 CMR 15.05 and 360 CMR 10.000.
- B. Sewer Connection or Sewer Repair permits will be required for the installation of all exterior grease traps. Exterior grease traps shall be designed by a Massachusetts Registered Professional Engineer and submitted for review and approval prior to the issuance of a permit.
- C. Exterior grease traps shall be installed by a Drainlayer licensed in the Town of Dedham.
- D. Each food service establishment (FSE) shall have their own individual exterior grease trap. Multiple food service establishments shall not be allowed to share a single exterior grease trap unless approved by the Board of Health along with an approved operation and maintenance agreement between all FSEs to share the exterior grease trap.
- E. Exterior grease trap capacities shall be calculated in accordance with the System Sewage Flow Design Criteria set forth in 310 CMR 15.203 of the State Environmental Code, Title 5. At a minimum, exterior grease traps shall have a capacity of not less than 1,500 gallons and shall sufficient capacity to provide at least a 24 hour detention period for the kitchen flows.
- F. All grease traps shall be installed on the exterior of the building and shall be located as to be readily and easily accessible for cleaning and inspection. Grease traps shall not be installed unless tested, rated and bear the seal of acceptance from the State Plumbing Board or approved by the Director.
- G. Installation of a grease trap shall require the installation of an inspection manhole, immediately downstream of the grease trap and a cleanout manhole located upstream of the exterior grease trap located between the building foundation and the exterior grease trap. This inspection and cleanout manholes shall be used to confirm the serviceability of the grease trap.
- H. Where preliminary treatment or flow-equalizing facilities are provided for any waters or wastes, they shall be maintained continuously in satisfactory and effective operation by the owner at his own expense and reported to the Dedham Sewer Department on an annual basis.
- I. Grease traps shall be equipped with devices to control the rate of water flow through the traps so that the flow rate does not exceed the rated design flow of the grease traps.

- J. Grease traps shall conform to the latest version of the Town of Dedham Design and Construction Standards and will require a grease monitoring system comprised of alarms and/or remote monitoring devices. Examples of grease monitoring systems approved by the Town include:
1. Ploylok's PL-625 Effluent Filter with Filter Alarm Panel and SmartFilter Control Switch. www.polylok.com , Or Equivalent
 2. Greasewatch3 Remote Tank Monitoring System. www.atsgreasewatch.com , Or Equivalent

The Town will require submittals for "or equivalent" grease monitoring systems for review and approval.

- K. The waste from food and waste grinders shall not discharge to the sewer system through a grease trap or otherwise.
- L. The use of water-cooled grease traps is prohibited.
- M. In the maintaining of these grease traps, the owner(s) shall be responsible for the proper removal and disposal by appropriate means of the captured material and shall maintain records of dates and means of disposal that are subject to review by the Director and the Board of Health. Licensed waste disposal firms must perform any removal and handling of the collected materials.
- N. Failure to properly maintain a grease trap shall be a violation of these Regulations.

5.1.5 Industrial Connections

When required, the owner of any property serviced by a building sewer carrying industrial wastes shall install a suitable control manhole together with such necessary meters, and other appurtenances in the building sewer to facilitate observation, sampling, and measurement of wastes. Such manhole, when required, shall be accessible and safely located and shall be maintained by the owner so as to be safe and accessible at all times.

The Director or other duly authorized employees or agents are authorized to obtain information concerning industrial processes which have a direct bearing on the kind and source of discharge to the wastewater facilities. The industry may withhold information considered confidential. However, the industry must establish that disclosure of the information in question to the public might result in an advantage to competitors.

5.1.6 Inspection

- A. At the time of inspection, the sewer shall be connected to the building plumbing. The Town shall inspect all work and the final connection before any portion of sewer is backfilled. All pipe installed shall be inspected by the Director or his designee prior to approval. The pipe shall be bedded and backfilled to the springline of the pipe with the specified 3/4-inch crushed stone. Once the pipe has been inspected, the Registered Drainlayer may then complete the stone and gravel backfill as specified above. No stones or other materials greater than 6 inches shall

be allowed within the backfilled trench. The Registered Drainlayer shall contact the Engineering Department a minimum of 24 hours prior to the inspection request, and notify the department when they are to begin work.

- B. The Director and other duly authorized employees or agents of the Town bearing proper credentials and identification shall be permitted to enter all private properties through which the Town holds an easement for the purposes of, but not limited to, inspection, observation, measurement, sampling, repair and maintenance of any portion of the wastewater facilities or storm drain facilities lying within said easement. All entry and subsequent work, if any, on said easement shall be done in full accordance with the terms of the easement pertaining to the private property involved.
- C. At the time of inspection, the Drainlayer shall have prepared an As-Built sketch of the service connection. The as-built shall include three measurements to a fixed location for the connection at the property line, cleanouts, bends, and Fernco.

5.1.7 Grinder Pumps and Sewage Ejectors

In cases where the existing sewer will not drain by gravity to the sewerage system, a pump system shall be designed and installed in accordance with Section 5.5.

5.1.8 Testing of Service Connections

Vacuum Testing will be required for all manholes (See Section 6). Air pressure tests may be required in some circumstances or when private sewer mains have been installed on a lot or estate as part of a permitted sewer connection (See Section 6).

5.2 Sewer Extension Permit

5.2.1 Design

All sewer extensions shall be designed by a Massachusetts Registered Professional Engineer in accordance with TR-16, The Town of Dedham Sewer Regulations and the DPW's "Design and Construction Standards". All sizes, slopes and materials are to adhere to TR-16. A plan and profile along with associated details of the sewer extension shall be submitted to the Director with the permit application for review.

5.2.2 Master Plan

All sewer extensions shall be designed to conform to the current Town of Dedham Sewer Master Plan. In no case shall a sewer extension be approved or installed unless the proposed sewer provides the proper sewer pipe material, size, depth, and alignment to achieve the current and future goals or intent of the Master Plan.

In the absence of a Master Plan, or as an interpretation or clarification thereto, the Director may reasonably require a particular material, size, depth and alignment of a proposed sewer extension be modified to allow for future sewer service.

5.2.3 Future Connections

Where a sewer main is to be laid in front of or adjacent to a property, a provision for future connection(s) of that property shall be provided by the Contractor and recorded with the Dedham Engineering Department.

For future connections of Building Sewers to the sewer main extension, wye connections shall be installed adjacent to each property that the sewer extension passes. If a way is intended to be permanently patched, paved, or otherwise improved such that there may be a moratorium imposed on future street opening permits, the Director may require that laterals be installed, in lieu of wyes, to existing homes or vacant lots. Laterals shall extend past the proposed edge of pavement, preferably to the property line. A standard 2"x4" with the top four feet painted green must be installed at the end of the plugged wyes or laterals and the locations of each shall be recorded on the as-built plan.

5.2.4 Minimum Size

No public gravity sewer shall be less than eight inches (20 cm) in diameter.

5.2.5 Depth

In general, sewers should be designed deep enough to drain basement fixtures and to prevent freezing. Insulation shall be provided for sewers that cannot be placed at a minimum depth of three (3) feet. This minimum depth shall be taken as the distance from the existing ground surface to the top of the pipe.

5.2.6 Slope

All sewers should be so designed and constructed to give a velocity when flowing full of not less than 2.0 feet per second (0.61 m/s) based on Manning's formula using an "n" value of 0.013. Use of other "n" values may be permitted by the reviewing agency if deemed justifiable on the basis of research or field data presented. The following minimum slopes may be used only if absolutely necessary because of grade restrictions; however slopes greater than these are desirable.

Sewer Size	Minimum Slope in Feet Per Feet (m/m)
8 inch (203mm)	0.004
10 inch (254mm)	0.0028
12 inch (305mm)	0.0022
14 inch (356mm)	0.0017
15 inch (381mm)	0.0015
16 inch (406mm)	0.0014
18 inch (457mm)	0.0012
21 inch (533mm)	0.0010
24 inch (610mm)	0.0008

27 inch (686mm)	0.00067
30 inch (762mm)	0.00058
36 inch (914mm)	0.00046

5.2.7 Minimize Solids Deposition

The pipe diameter and slope shall be selected to obtain the greatest practical velocities to minimize settling problems. Oversizing of sewers in order to justify using flatter slopes is discouraged. If the proposed slope is less than the minimum slope of the smallest pipe which can accommodate the design peak hourly flow, the actual depths and velocities at minimum, average and maximum day and peak hourly flow for each design section of the sewer shall be calculated by the design engineer and submitted to the reviewing authority.

5.2.8 Slope Between Manholes

Sewers shall be laid with uniform slope between manholes.

5.2.9 High Velocity Protection

Velocities greater than 12 feet per second (3.7 m/s) will not be permitted under any flow conditions, unless adequate special provision is made to protect against displacement by erosion and impact.

5.2.10 Steep Slope Protection

Sewers on 15 percent slopes or greater shall be anchored securely to prevent displacement.

5.2.11 Impervious Dams

Impervious dams shall be provided every 300 feet or between each manhole to manhole segment to control the flow of groundwater within the pipe bedding material.

5.2.12 Alignment

In general, sewers 30 inches or less in diameter should be laid out in a straight line and alignment should be checked with a laser beam.

5.2.13 Changes in Pipe Size

When a smaller sewer joins one of a larger diameter, the invert of the smaller sewer should be raised sufficiently to maintain the same energy gradient. An approximate method for securing these results is to match crowns.

5.2.14 Manhole Locations

Manholes shall be installed at the end of each line; at all changes in grade, size or alignment; at all intersections; and distances not greater than 300 feet for sewers 15 inches or less in diameter, and 500 feet for sewers 18 to 42 inches in diameter. Greater spacing may be permitted between manholes and sewers carrying a settled effluent, with prior approval of the reviewing agency.

5.3 Sewer Repair Permit

- 5.3.1** If any private sewer service connection or main becomes obstructed or otherwise fails to work properly, notice must be given to the Director or his duly authorized agent. If maintenance or repair work is necessary on private property or on the building sewer between a building and the connection to the public sewer main, the owner shall pay the cost of such work. Repair work or maintenance of the public sewer system on Town Property or within a Town easement will be performed and paid for by the Town of Dedham. The property owner(s) affected shall be responsible to determine that the obstruction is not on his property or in his building sewer. In no way will the Town pay for or reimburse any owner or Drainlayer who performs work on private property as a result of a blockage or maintenance issue on Town property.
- 5.3.2** A Dedham Sewer Repair Permit must be issued before the repair of any sewer service, main, manhole or other appurtenance. A completed sketch of the proposed repair shall be included with the Sewer Repair Permit application. This sketch shall show the general alignment of the sewer including any bends, clean-outs, or manholes. The sketch shall also show the proximity of the sewer line to any significant features such as buildings, structures, paved areas, and water lines.
- 5.3.3** At the time of inspection, the Drainlayer shall have prepared an as-built sketch of the repair. The as-built shall include three measurements to a fixed location for the connection to existing pipes, cleanouts, and bends.
- 5.3.4** The Director may require that a clean-out be installed as part of any physical repair performed, regardless of the scope of the repair, if a clean-out does not exist.

5.4 Sewer Disconnection Permit

Prior to the demolition of any building or structure that is connected to the sewer system; the sewer service for that building or structure must be permanently capped at the sewer main or at another location with the approval of the Director. A Registered Drainlayer shall obtain a Sewer Disconnection Permit for the work, and the work shall be inspected and as-built plan submitted in the same manner as described in Section 4.1.

5.4.1 Credit for Existing Flow

For buildings being demolished for the purpose of constructing a new building or buildings on the same lot, the estimated average daily flow per 314 CMR 7.15 of the existing structure will be credited towards the proposed average daily flow of the proposed structure(s) in the fee calculation as provided in Appendix A under the following circumstances:

- The existing building(s) was in existence and connected to Town sewer within two (2) years of the new building Sewer Connection Permit application;
- The existing buildings(s) are located on the same lot;
- A valid Disconnection Permit was issued prior to demolition.

However, in no event will a credit be issued or refund given if the proposed flow is less than the existing flow.

6.0 Technical Requirements

6.1 Trench Excavation and Backfill

6.1.1 Traffic Control & Safety

- A. All excavations for sewer installation shall be adequately guarded with barricades and lights so as to protect the public from hazard. Streets, sidewalks, parkways and other public property disturbed in the course of the work shall be restored in a manner satisfactory to the Town.
- B. If work is being performed in a traveled way, it shall be at the discretion of the Chief of Police to require an assigned Police Detail to any and all work performed in the travel way.
- C. Any work within a State Highway shall be coordinated with the Massachusetts Highway Department.

6.1.2 Materials

A. Trench Backfill

Trench backfilling operations performed within the Town's Right-of-Way or paved areas shall be backfilled in accordance with the DPW's Street Opening Permit.

Trench backfilling operations performed out of the Town's Right-of-Way or paved areas shall consist of the placement and compaction of common backfill material. No backfill shall be placed on or against structures, pipes, or any other masonry until the Dedham Engineering Department or its authorized agent has performed a visual inspection. Unacceptable material shall be removed at the direction of the Director.

B. Crushed Stone

Material for pipe bedding shall be 3/4 inch minus crushed stone, having reasonably even gradation from coarse to fine, in accordance with the Massachusetts Highway Department Standard Specifications for Highways and Bridges specification for Aggregates and related materials M2.010 (Sect. 230.61).

C. Common Backfill Material

Common backfill material is herein classified as the material generated during trench excavation operations. This material may be reused for trench backfill, within the approved areas as indicted above, provided that

all stones greater than 4 inches in diameter are removed from the material prior to placement and compaction.

D. Bituminous Concrete

Asphaltic concrete shall be hot plant mix, type I-1 material conforming to the requirements of MA Highway Section 420, entitled, "Class I Bituminous Concrete Base Course" of the Standard Specifications of the Massachusetts Highway Dept. Contractor shall replace bituminous concrete in two lifts, binder and wearing course in thickness' as specified by the DPW's "Design and Construction Standards, but in no case less than 2" binder and 1.5" wearing course.

6.2 General Construction

6.2.1 Clearing the Right of Way

Where clearing of the right of way is necessary, it shall be completed prior to the start of the trenching. Trees and brush shall be cut as near to the surface of the ground as practicable and piled for disposal. Contractor shall remove all organic material, grub stumps and strip loam & subsoil to granular mineral material. The Contractor shall observe all state laws relating to fire permits and local regulations relating to burning such materials. Under no conditions shall excavated materials be permitted to cover brush or trees prior to clearing and disposal. In accordance with Massachusetts Highway Dept. Standard Specifications (Sect 101).

6.2.2 Pavement Removal and Replacement

All bituminous and concrete pavements, regardless of the thickness, shall be saw-cut where required prior to excavation of trenches. Width of the pavement cut shall be at least six (6) inches greater than the required width of the trench at ground surface on each side. Pavement removed during excavation shall be piled separately from the earth spoil and removed from the site and shall not be used in backfilling the trench. After the trench has been backfilled and compacted according to the design specifications, the Contractor shall bring the trench to a smooth even grade at the proper depth below the existing surface to provide for the required depth of pavement. The Contractor shall saw-cut the existing pavement to a straight line and remove any pavement that has been damaged during work as required by the Director of Public Works and or the Director. The entire existing paved surface shall be cleaned and the sawn edges prepared with tack before resurfacing is begun. The trench shall be repaired per the specifications set forth in the Street Opening Permit issued by the Dedham Department of Public Works.

6.2.3 Blasting

Blasting for excavation will be permitted only after securing approval of the Dedham Fire Department and only when proper precautions are taken for the protection of persons and property. The Contractor at his own expense shall repair

any damages caused by the blasting. The Contractor's methods of procedure and blasting shall conform to all applicable State laws and municipal ordinances.

6.2.4 Trench Width

In all cases, trench width shall be confined to dedicated right-of-way for public thoroughfares or within areas for which construction easements have been obtained, unless special arrangements have been made with the affected property owners beforehand and approved by the Engineering Department.

6.2.5 Grade

The bottom of the trench shall be carried to the lines and grades shown on the Plans or as established by the design Engineer, with proper allowance for pipe thickness and for proper bedding.

6.2.6 Shoring, Sheet piling, and Boxing of Trenches

Whenever necessary to prevent caving during excavation in gravel, sandy soil, or other unstable material, the trench shall be adequately sheeted and braced. Failure to comply with proper applicable OSHA standards with regard to; sheet piling, shoring, or bracing shall be cause for a Notice of Violation. All sheet piling, shoring and bracing of trenches shall conform to those standard requirements.

6.2.7 Location of Excavated Materials

During trench excavation, the Contractor shall locate the excavated material so it will not obstruct a traveled roadway or street; and, unless otherwise approved by the Director, all streets and roadways shall be kept open to at least one-way traffic, or as directed by the Dedham Police Department.

6.2.8 Debris

No groundwater, septic water, gravel, stones, etc. shall enter the Sewer during construction. The Registered Drainlayer shall be responsible to protect the Sewers from these occurrences.

6.2.9 Safety

The Registered Drainlayer shall be responsible for the proper excavation and safety measures during construction. All work shall be in accordance with OSHA standards. The Town of Dedham is not responsible for proper safety standards employed by the Registered Drainlayer and accepts no responsibility for accidents.

6.2.10 Removal of Water

- A. The Contractor shall provide and maintain ample means and devices with which to promptly remove and properly dispose of all water, including flow from existing sewer lines, entering the trench excavation during the time the trench is being prepared for the pipe laying, during the laying of

the pipe, and inspection, until the backfill above the pipe has been completed accordingly.

- B. The Contractor shall be responsible for dewatering the trench. If the Contractor wishes to dewater into the Towns drainage system, the Dedham Engineering Department must approve any and all means for the transfer, treatment and disposal thereof before any discharge occurs.
- C. The Contractor shall dispose of the water and or sewage in accordance with state and local regulations. Precautions against sedimentation control must be maintained at all times.

6.2.11 Trench Backfill Compaction

After the Contractor has backfilled the pipe zone of the trench as required, he shall then backfill the balance of the trench, mechanically compacting each layer to 95% of maximum density in roadways and 90% in all other areas. Where fill is required, use approved backfill material as indicated in Section 6.1.2.

6.2.12 Excess Excavated Material

All excess excavated materials shall be hauled and properly disposed of by the Contractor. The Contractor shall make his own arrangements for the disposal of the excavated material.

6.2.13 Rock Excavation

Before proceeding with rock excavation, the Contractor shall have completed the common excavation to such depths that only rock excavation remains. At this time the trench shall be made available to the design Engineer and measurements will be taken to determine the amount of rock excavation remaining. Any redirection of a sewer connection to avoid ledge outcrops must be approved by the Engineering Department.

6.2.14 Controlled Density Fill

Controlled Density Fill (CDF) where required, shall be a mixture of Portland cement, fly ash, aggregates, water and admixtures proportioned to provide a non-segregating, self consolidating, free-flowing and excavatable material that will result in a hardened, dense, non-settling fill. CDF is approved as an alternative to "Gravel for Trench Backfill."

The use of CDF as approved backfill material shall be performed as indicated in the Street Opening Permit.

Contractor shall provide steel plates k-36 steel (k-56 recommended) to span trenches or otherwise prevent traffic or construction equipment coming in contact with CDF until the CDF has hardened sufficiently to prevent rutting. Contractor shall provide cold patch on all edges of steel plates used for vehicular transition in any affected area.

6.3 Sewer Pipe Installation

6.3.1 Scope

This item shall include the work necessary for the installation of sewer pipe and fittings of the sizes and classes indicated, including but not limited to furnishing materials, placing crushed gravel pipe base, providing bell holes in the trench bottom; laying and jointing the pipe; installing sewer tees, wyes and laterals; furnishing pipe necessary for physical test; and testing of the line. Ductile iron pipe shall be used when the sewer line is to be located less than three (3) feet below existing finished grade.

6.3.2 Materials

All materials used in new sewer construction must have a useful design life of 50 to 100 years. The use of pipe, couplings, or any other material that does not meet the design life requirement is prohibited.

A. PVC Sewer Pipe

Pipe used for sewers shall be PVC. The pipe shall be of the size and type indicated on the plans and shall conform to the appropriate specifications detailed below. Pipe and fittings used in Building Sewer construction shall be smooth wall inside and out, and must be either: Polyvinyl Chloride ("PVC") and must conform to ASTM D-3034 (SDR 35; or ASTM D-1785-99 (Schedules 40 or 80)). All pipe must have a minimum tensile strength of 34.50 Mpa as defined by ASTM D-1784. SDR rating is the ratio of the outside diameter to the pipe wall thickness.

B. Ductile Iron Pipe

Ductile iron (DI) pipe must meet ASTM A-746-99 (pressure class 350) or AWWA C-151 (pressure class 350) with exterior asphaltic coating per AWWA C-151 and interior asphaltic coating meeting AWWA C-151 or polyethylene lining complying with ASTM D-1248 of nominal 40-mil thickness.

6.3.3 Joints

All pipe joints shall be push-on types with proper gaskets for sealing the Sewer. Where push-on joints are not feasible, rigid slip couplings or mechanical joint couplings shall be used. Except for joining the building plumbing to the lateral sewer, Fernco type joints will only be allowed with prior approval of the Director. When Fernco joints are used they shall be provided with stainless steel shear bands or encased in concrete to prevent joint settlement and separation.

6.3.4 Preparation of Trench

Crushed stone base for pipe shall be placed in the trench to a minimum depth of six (6) inches below the invert of the pipe. The base shall be placed and leveled to approximate flow line grade in advance of the pipe laying. Immediately following the placement of each pipe, the crushed gravel pipe base shall be placed to the centerline of the pipe and properly chinked.

6.3.5 Preparation of Sewer Pipe

All pipes and fittings shall be carefully inspected before being laid and no cracked, broken or defective pipe or fittings shall be used in the work. The ends of the pipe shall be cleaned with a brush, washed and thoroughly scrubbed where necessary to remove dirt or other foreign material.

Extreme care shall be exercised to insure that the inside surfaces of the bell are smooth and free from any projections which would interfere with the assembly or water tightness of the joint.

6.3.6 Laying and Jointing Pipe and Fittings

- A. Sewer pipe shall be laid in full lengths as manufactured and shall be laid on a constant grade and in a straight alignment from manhole to manhole or clean-out. Wherever possible, pipe shall not be installed with elbows or bends. A manhole shall be located at every change in grade or horizontal alignment, but no more than three hundred (300) feet apart unless approved by the Director.
- B. The Contractor shall layout his own work and be responsible for the execution of the work to such lines and grades to comply with the specifications stated herein.
- C. PVC pipe is flexible in nature and may be out of grade and alignment through the middle of a pipe length even though each end is on grade and in alignment as evidenced by a laser beam or grade boards. To prevent the above situation from occurring, the contractor shall check the elevation of the top of each length of PVC pipe laid at each end and at the midpoint. The midpoint elevation shall be within 0.01 foot of the average elevation of the two ends.

6.3.7 Sewer Installation

- A. PVC Sewer Pipe shall be installed in accordance with the manufacturers recommended installation procedures.
- B. PVC Sewer Pipe shall be connected to concrete manholes by means of an approved coupling with an elastomeric gasket, an approved waterstop or flexible sleeve. Use of Portland Cement grout for connecting PVC Sewer Pipe to manholes will not be permitted, unless previously authorized by the Director. Pipe laying shall proceed upgrade with the bell ends of bell and spigot pipe pointing in the direction of flow (uphill). Each piece shall be laid true to line and grade and in such a manner as to form a closed

concentric joint with the adjoining pipe in order to prevent any sudden offsets in the flowline.

- C. **Main Sewers**
All Sewer mains shall be installed using a laser or other approved means to insure correct line and grade. The Registered Drainlayer is responsible for the line and grade of the pipe.
- D. The installation of sewer pipe shall commence at the lowest point along the sewer and shall proceed so that the spigot end of the section being laid is placed into the bell end of the pipe already laid. Every precaution shall be taken to prevent foreign materials from entering the pipe while it is being placed in the trench. During laying operations, no debris, tools, clothing or other materials shall be placed in the pipe. The Engineering Department shall inspect any and all piping before backfilling occurs. No de-watering of the trench shall take place into the sewer pipe or any appurtenance.
- E. Sewer pipe shall be bedded in $\frac{3}{4}$ inch crushed stone six inches above and below the pipe and at full width of the trench. The drainlayer shall backfill the sewer line with approved material, which is free of stones larger than six inches or 50 pounds.
- F. **Service Connections**
The Contractor shall place service lateral Wye branches at the locations indicated on the plans or specified by the Engineering Department. Sewer laterals shall be provided for every home or buildable lot. Final service lateral locations may be determined in the field after consultation with the property owner. The 6-inch side outlet shall be installed at an angle of approximately 45 degrees above the horizontal. After the Wye is in position, special pipe bedding material and select backfill shall be hand-placed and chinked around the Wye to prevent any movement of the next pipe.
- G. The Wye outlet shall be plugged with a 6-inch plug and marked with a standard 2"x4" painted green.
- H. Upon completion of the sewer, a Registered Professional Engineer shall complete an as built plan and profile drawing. The plan shall show, at a minimum, the location of all sewer lines, manholes, laterals, ties to each lateral, depth of each lateral, and map and lot numbers. The Drainlayer shall be responsible for recording lateral information. If information is not available at the time of the as built the Drainlayer shall excavate and uncover laterals as necessary.
- I. **General**
No gravity sewer, lateral connection, or sewer manhole shall allow the introduction of rainwater, surface drainage, groundwater or any other source of inflow to the sewer system.

- J. No transition of pipe diameter or material is allowed between manhole sections, unless approved by the Director.
- K. Gravity sewers shall be installed in the centerline of the road as much as practicable to prevent conflict with other utilities.
- J. If, due to topography, the sewer is more than approximately three (3) feet deeper than is required for the service connection depth, then a chimney is to be used to reduce the depth and associated cost of the lateral service connection. Refer to the DPW's "Design and Construction Standards" for installing chimneys.
- K. All new sewer mains shall be cleaned and camera inspected prior to acceptance by the Town.

6.3.8 Testing of Sewer Pipe & Appurtenances

After completion of the sewer main and all laterals, the Drainlayer shall hire an approved independent testing service to conduct low-pressure air leakage tests on all sections of new sewer and negative air pressure tests on all new manholes using ASTM and Town of Dedham Standards outlined in Section 7 of this document.

Prior to final operation of a sewer main extension or building sewer, the Director may also require the following additional testing to identify defects and/or sources of infiltration/inflow (I/I):

- i. Video camera inspection of all lines in the presence of the Engineering Department.
- ii. Smoke testing of all lines in the presence of the Engineering Department.
- iii. Deflection testing of all lines in the presence of the Engineering Department.
- iv. Site inspection of the Owner's Premises, including the interior of the building

6.4 Manhole and Clean-out Construction

6.4.1 Concrete

Manholes shall be pre-cast concrete with O-ring or bituminous-based gasketed joints or poured-in place concrete type. Other types are allowable subject to the approval of the reviewing agency. Concrete used in the construction of the manhole shall be so proportioned and mixed as to meet a 3,000-psi compression test after 28 days.

6.4.2 Precast Manhole Sections

Precast concrete sections for manholes shall be minimum of 48 inches in interior diameter. Cones shall be eccentric with a wall thickness of a minimum of five (5) inches and reinforcement similar to that of manhole sections. The tops and bottoms

of the cones shall be parallel. Any manhole having a depth greater than nine (9) feet shall have an extended base.

6.4.3 Special Fittings

The wyes, tees, and bends used in the construction of the drop manholes assembly and the clean-outs shall be either PVC or ductile iron. The pipe and fittings shall conform to the specifications as set forth in these Specifications. Drop manhole assemblies shall be encased in concrete or as required by the Director.

6.4.4 Drop Manholes

A drop pipe should be provided for a sewer, with an invert entering a manhole at an elevation of 24 inches (61 cm) or more above the manhole invert. Where the difference in elevation between the incoming sewer and the manhole invert is less than 24 inches (61 cm), the invert shall be filleted to prevent solids deposition. Drop manholes should be constructed with an outside drop connection where appropriate. Outside drop connections shall be encased in concrete. Inside drop connections, where necessary, shall be secured to the interior wall of the manhole and provide access for cleaning. Inside drop manholes will only be allowed if the manhole diameter is 60 inches or greater.

6.4.5 Manhole Frames and Covers

All manhole frames and grates shall be either LeBaron Foundry model LK110 or LC type with a minimum clear opening of 24 inches, or an approved equal meeting the following minimum standards:

All manhole frames and covers shall be of a size and shape detailed on the plans or approved equal. The castings shall be tough, close-grained, gray iron, free from blowholes, shrinkage and cold shuts. They shall conform to ASTM A 48 - Class 30 and shall be sound, smooth, clean and free from blisters and all defects. All castings shall be planed and ground where necessary to ensure perfectly flat and true surfaces. Covers shall be true and shall seat within the ring at all points. Manhole covers shall have a maximum of two (2) holes.

All Manholes shall have the word "SEWER", cast upon the cover and be American made.

6.4.6 Watertightness

Solid manhole covers shall be used and watertight manhole covers are to be used in areas subject to flooding. Manhole lift holes and grade adjustment rings shall be sealed with a non-shrinking mortar or other material approved by the reviewing agency. Inlet and outlet pipes shall be joined to the manhole with a gasketed flexible watertight connection or other watertight connection arrangement that allows differential settlement of the pipe and the manhole to take place.

6.4.7 Coating

The exterior surfaces of all manholes shall be given two (2) heavy coats of bituminous waterproofing material.

6.4.8 Manhole Steps

Steps for precast manholes shall be of steel reinforced polypropylene plastic, or approved equal. All steps shall be in conformance with ASTM C-478 and shall be aligned vertically. All steps within a manhole shall be of the same design, type and size. Mixing of unmatched steps within the same manhole is not permitted.

Steps shall be placed where there are no incoming or outgoing lines. Loose steps shall be cause for rejection of that manhole cone or section.

6.4.9 Manhole Stubs

Provide plugged manhole stubs for sewer extensions as shown on the plan or as required by the Engineering Department. The intent of the plugged stub is to provide a means by which future sewer lines can be connected to the manhole with a minimum of inconvenience. Construct invert channels to the manhole wall at the plugged stub in accordance with the invert elevation directed by the design Engineer.

6.4.10 Manhole Bench (Table)

A bench shall be provided on each side of any manhole channel wherever practical. The bench should be sloped no less than ½ inch (13 mm) per foot (305 mm) (4 percent) or greater than 1.0 inch per foot. No lateral sewer, service connection, or drop manhole pipe shall discharge onto the surface of the bench.

6.4.11 Manhole Inverts (Flow Channel)

The manhole inverts shall provide a smooth flow-through characteristic. No sharp edges or rough sections that will tend to obstruct the flow of sewerage will be permitted. All cement mortar used in the construction of the inverts shall be troweled smooth. The flow channel through the manholes shall be made to conform in shape and slope to that of the sewers entering and leaving the manholes. The top of the flow channel shall be constructed so that under the peak design conditions the flow will remain in the channel. The channel walls should be formed or shaped to the full height of the crown of the outlet sewer in such a manner to not obstruct maintenance, inspection or flow in the sewers. When curved flow channels are required in manholes, including branch inlets, minimum slopes should be increased to maintain acceptable velocities. A minimum 0.1' drop shall be provided through the manhole.

Inverts shall be constructed of brick and mortar. The brick shall be sound, hard and uniformly burned brick, regular and uniform in shape and size, of compact texture, and satisfactory to the Director. Designation M32-73, AASHO M91-42, red sewer brick only Grade S.A. Brick shall comply with the ASTM Standard Specification of sewer and manhole brick (made from clay or shale). The mortar shall be composed of Portland cement, hydrated lime and sand in which the volume

of sand shall not exceed three (3) times the sum of the volume of cement and lime. The proportions of cement and lime shall be 1:1/4.

6.4.12 Buoyancy

Buoyancy of manholes shall be considered and floatation shall be prevented with appropriate construction where high groundwater conditions are anticipated.

6.5 Grinder Pumps and Sewage Ejectors

6.5.1 In cases where the existing sewer will not drain by gravity to the sewerage system, a pump system shall be employed. A pump system shall consist of a precast pump chamber, with a minimum storage capacity of 24 hours of the design flow. A 0.5 horsepower grinder style pump and a piped connection rated for pressure in excess of 150 PSI shall be utilized.

6.5.2 All low-pressure sewers are to be designed by a Massachusetts Registered Professional Engineer in accordance with TR-16.

6.5.3 The low-pressure sewer line shall be bedded in clean sand.

6.5.4 For systems connecting to a low-pressure sewer main, a curb box type shut off valve shall be provided at the property line.

6.5.5 Force main connections to the Dedham Sewer System shall be allowed only as approved by the Director. At no time shall a Sewer Force Main tie directly into any gravity Dedham Sewer Main. The force main shall connect to a sewer manhole on private property, and then the connection shall flow by gravity to the existing sewer main.

6.5.6 Pumps must be external to the building and situated in a 1,000-gallon pre-cast tank (minimum). Any backup into the building will be the sole responsibility of the Property Owner. The Town of Dedham is not liable or responsible in any way for damages due to sewage backups served by grinder/ejector pumps, or the force main line itself. The operations, maintenance, repair and replacement of the pump and appurtenances shall be the sole responsibility of the Homeowner. This also includes the force main and/or gravity Sewer from the building to its connection into the Dedham Sewer main or service lateral.

6.5.7 Wiring and electrical connections should be NEMA rated for the environment in which they are to be placed.

6.5.8 Level sensing devices should be used to detect wastewater levels for initiating pump operation and to detect high water levels. Level sensing devices are recommended over mercury float-type switches. These devices should not be located near flows entering the well.

6.5.9 Inspection of pump system shall be performed by the Engineering Department. Contractor shall provide water and shall run the pump through several cycles. Connection shall be inspected for workmanship and materials, and either be passed

or failed at the time of inspection. The Town of Dedham Building Department shall inspect all wiring.

6.6 Pressure Sewer Systems

Wastewater can be conveyed to the pressure sewer using various approaches, such as septic tank effluent pumping (STEP) or grinder pumps. A pressure main is common to both systems. In addition, components such as isolation valves, air release valves, and cleanouts make up a pressure sewer system.

6.6.1 Layout

The branched configuration of a pressure sewer is similar to that of a conventional gravity sewer system. Looped piping is not permitted. Pipe routing should include long radius sweeps no less than those recommended by the pipe manufacturer. Pressure pipes should be deep enough to prevent freezing.

6.6.2 Pipe Size

Size the diameter of the pressure sewer so that it provides a cleansing velocity based on the average daily flow of the system.

6.6.3 Pipe Material

Use the equivalent of Class 200, SDR 21 PVC piping or greater in pressure sewers to provide the necessary working pressure rating for the system, and to provide durability during installation.

6.6.4 Valves

Curb box shut off valves shall be provided at the property line on each service line. In addition, isolation valves should be considered where system expansion is projected, and at key locations on very long runs.

6.6.5 Air Release Valves

To release air trapped in the pressure lines, site air release valves at high points in the system. Air release valves should be located in a manhole or structure to allow access for repair and maintenance. Consider automatic air release valves to reduce the system's operating and maintenance costs.

Also, place air release manholes at least 14 pipe diameters downstream of the locations where hydraulic jumps occur. Hydraulic "jumps" form in sections where the pipeline intersects with the hydraulic grade line. Air bubbles formed by hydraulic jump conditions are carried downstream with the wastewater flow.

6.6.6 Cleanout Connections

Provide a means for cleaning out the pressure mains at sags and other locations where debris can accumulate and clog the lines. Provide proper valving to conduct required maintenance.

6.7 Wastewater Pumping Stations and Force Mains

All wastewater pumping stations and force mains shall be designed by a professional engineer in accordance with TR-16.

6.8 Trenchless Technology

All sewers installed using trenchless methods must be designed by a Massachusetts Professional Engineer, and must conform to slope, grade, and alignment as specified in these regulations. Any alternate materials used in trenchless technologies must meet the minimum requirements as specified in these regulations for conventional materials. The Director will review any proposed trenchless technology on a case-by-case basis.

6.8.1 Existing Utilities

In preparation of pipe jacking or directional drilling activities, an as-built showing any and all existing utilities in the area of work must be verified by test pits or by vacuum hole methods. These field locations must be submitted in lieu of any proposed sewer work.

6.8.2 Pipe Jacking

A specialized tunneling method for installing underground pipelines with minimal surface disruption. Primarily used for new sewer construction, it is also used for sewer replacement and relining.

6.8.3 Horizontal Directional Drilling

Horizontal Directional Drilling (HDD) is a trenchless method for installing any number of utilities. It is a multi-stage process consisting of site preparation, and restoration, equipment setup, and drilling a pilot bore along a predetermined path and then pulling the product back through the drilled space. Alignment of the bore is accomplished by a hydraulic jack as the drill bit head is pushed into the ground. The orientation and tracking of the head is determined by an above ground radio detection device, which picks up radio signals generated from a transmitter on the drill itself.

Contractor is responsible for selecting or designing drilling fluids for the site-specific soil and groundwater conditions. Confine free flowing (escaping) slurry or drilling fluids at the ground surface during pull-back or drilling. This can be accomplished by creating sump areas or vacuum operations to prevent damage or hazardous conditions in surrounding areas.

6.8.4 Boring Path Report

Furnish a Bore Path Report to the Engineering Department within seven (7) days of the completion of each bore path. Include the following in the report:

1. Location of project including the Permit Number and when assigned.
2. Name of person collecting the data, including title, position and company name.
3. Investigation site location.
4. Identification of the detection method used.
5. Elevations and offset dimensions as required.

6.8.5 As-Built Trenchless Sewers

Any sewers installed by trenchless methods must meet the required minimum slopes, alignment, and grade as proposed in the original design plans. Any sewers that do not meet the minimum requirements shall be rejected.

7.0 Sewer Testing

7.1 Low Pressure Air Testing

- 7.1.1 All new sewer mains, and services where required, must successfully pass an air leakage test as described in this section.
- 7.1.2 At the time of the test, the Registered Drainlayer shall determine the groundwater elevation from observation wells, excavations or other means, all subject to review by the Director.
- 7.1.3 For making the low-pressure air test, the testing service shall use equipment specifically designed and manufactured for the purpose of testing sewer pipelines using low-pressure air. The equipment shall be provided with an air regulatory valve or air safety so set that the internal air pressure in the pipeline cannot exceed 8 psig.
- 7.1.4 The leakage test using low-pressure air shall be made on each manhole-to-manhole section of pipeline and any stubs and stoppers after placement of the backfill.
- 7.1.5 The mainline pipe shall be tested after the contractor has completed the work described in the permit. If the Contractor is going to be installing laterals, then they should be installed as close to the building as practical and properly plugged for low pressure testing. If any connections are made to the building sewers it shall be the responsibility of the Drainlayer to temporarily disconnect or plug the connections.
- 7.1.6 Pneumatic plugs shall have a sealing length equal to or greater than the diameter of the pipe to be tested. Pneumatic plugs shall resist internal test pressures without requiring external bracing or blocking.
- 7.1.7 All air used shall pass through a single control panel.

- 7.1.8** Low-pressure air shall be introduced into the sealed line until the internal air pressure reaches 4 psig.
- 7.1.9** At least two (2) minutes shall be allowed for the air pressure to stabilize in the section under test. After the stabilization period, the low-pressure air supply hose shall be quickly disconnected from the control panel. The time required in minutes for the pressure in the section under test to decrease from 4 to 3 psig shall not be less than that shown in the following table.

Pipe Diameter in Inches	Minutes
6	5:40
8	7:36
10	9:26
12	11:20
15	14:10
18	17:00
21	19:50
24	22:40
27	25:30

- 7.1.10** Should the sections under test fail to meet the requirements, the Registered Drainlayer shall do all work of locating and repairing leaks and retesting as the Director may require.

7.2 Vacuum Test (Negative Air Pressure)

- 7.2.1** All manholes, wet wells, valve pits, grease traps, or any other structure or appurtenance other than sewer mains, laterals, and clean-outs, which are connected to the sanitary sewer system, must be tested by means of either vacuum or exfiltration testing. Exfiltration testing will only be allowed when in the opinion of the Director it is not feasible to conduct vacuum testing due to size and configuration of openings or extreme shallow depth of a structure.
- 7.2.2** All lift holes and pipes entering the manhole are to be plugged. A vacuum will be drawn and the vacuum drop over a specified period of time is used to determine the acceptability of the manhole (ASTM-C1244-93).
- 7.2.3** All manholes shall be made as tight as possible to prevent infiltration and inflow and to ensure no leaks are present.
- 7.2.4** The Director or his designee prior to testing shall inspect all manholes.
- 7.2.5** Manholes shall be tested using approved testing techniques and equipment described by the American Society for Testing Materials after all connections to the manhole have been made. Backfill is not required for manhole testing.

- 7.2.6 All manholes shall pass a Negative Air Pressure (Vacuum) Test as detailed below prior to approval by the Director or his designee.
- 7.2.7 All lift holes are to be permanently plugged and joints in sections and around entering pipes sealed.
- 7.2.8 All pipes entering the manhole are to be temporarily plugged taking care to securely brace the pipes and plugs to prevent them from being drawn into the manhole.
- 7.2.9 All manholes are to be individually tested, and the values obtained are applicable only to the manhole being tested at the time and conditions of testing.
- 7.2.10 The test head shall be placed on top of the manhole or inside the opening in accordance with the manufacturer's recommendation.
- 7.2.11 It is the responsibility of the drainlayer to ensure the manhole has a flat surface and testing head is able to make a tight seal.
- 7.2.12 If manhole cannot be tested due to leakage around testing head, necessary repairs shall be made and the manhole retested. In cases of retesting, the Director or his designee reserves the right to reschedule or delay the test to conform with his/her schedule.
- 7.2.13 A vacuum of ten (10) inches of mercury shall be drawn on the manhole, the valve on the vacuum line of the test head closed, and the vacuum pump shut off. The time shall be measured for the vacuum to drop from ten (10) inches of mercury to nine (9) inches.
- 7.2.14 The manhole shall pass if the time for the vacuum to drop from ten (10) inches to nine (9) inches of mercury meets or exceeds the value indicated in the following table.

Depth of manhole	Time (min)
Less than 10 feet	1
10 to 15 feet	1.5
Greater than 15 feet	2

- 7.2.15 Depth of a manhole is to be measured from the lowest inside elevation of the manhole to the surface on which the vacuum head is to be placed.
- 7.2.16 If the manhole fails the initial test, necessary repairs shall be made and the manhole retested. In cases of retesting, the Director or his designee reserves the right to reschedule or delay the test to conform with his/her schedule.
- 7.2.17 The Director or his designee may deem a manhole failed after successful completion of a vacuum test if water is observed in the manhole after completing the test or the level of standing water in a manhole rises after completing the test.

7.3 Exfiltration Testing

- 7.3.1** Maximum allowable exfiltration for new sanitary sewer sections or manholes is 200 gallons per inch of diameter per mile of pipe per day.
- 7.3.2** Exfiltration testing will not be allowed if the temperature of components is below 33 degrees Fahrenheit.
- 7.3.3** Plug all inlets and outlets.
- 7.3.4** The manhole or structure shall be completely filled with water to the top, or at a level as specified by the Director, but not less than 2 feet above ground water level.
- 7.3.5** The water level shall be clearly marked or measured from a reference point.
- 7.3.6** Allow water to stand in manhole for one hour, then refill to original water level and begin test.
- 7.3.7** After one hour, measure the drop in water level. For 48-inch diameter manhole, use measured water level drop to determine equivalent gallons lost per 24 hours from table in Section 6.3.8 (i.e. 2" drop = 376 gal; 2 1/4" drop = 423 gal.). For other manhole sizes, calculate the 24-hour equivalent loss using the formula stated therein.
- 7.3.8** Exfiltration Rate: The following table may be used to determine exfiltration in gallons per 24 hours by measuring loss that occurs in 1 hour. The table is applicable only for 48-inch diameter manholes.

Loss in Gallons Per 24 Hours for Drop in Water Level Per Hour in 48" Dia. Manhole										
DROP	0"	1"	2"	3"	4"	5"	6"	7"	8"	9"
	188	376	564	752	940	1128	1316	1504	1692	
1/4"	47	235	423	611	799	987	1175	1363	1551	1739
1/2"	94	282	470	658	846	1034	1222	1410	1598	1786
3/4"	141	329	517	705	893	1081	1269	1457	1645	1833

For manholes larger than 48" diameter use the following formula.

$$G = 0.0816(H)(D^2)$$

Where:

G = gallons drop in 24 hours in inches.

D = diameter of manhole in inches.

H = drop in manhole in inches.

- 7.3.9** The maximum allowable exfiltration (leakage) per 24 hours is 200 Gallons per inch per mile per day, or 0.003 gallons per foot of diameter per foot of depth.
- 7.3.10** Allowable exfiltration per day (Gallons) = 0.003 x Diameter (FT) x Depth (FT)

7.3.11 Test failure is indicated by water loss greater than maximum allowable exfiltration.

7.4 Force Main Testing

7.4.1 As a minimum, all sewer force mains shall be tested in accordance with the Hydrostatic Testing Requirements of AWWA C600.

7.4.2 All force mains shall be given a hydrostatic test of at least 1.5 times the shutoff head of the connected pumps or 150 psi, whichever is greater. Loss of water pressure during test shall not exceed 5 psi in a 2-hour period.

7.4.3 Where practicable, pipelines shall be tested between line valves or plugs in lengths of not more than 1500 feet.

7.4.4 The pipe shall be slowly filled with water and the specified test pressure shall be applied by means of a pump connected to the pipe. Before applying the specified test pressure, all air shall be expelled from the pipe. If permanent air vents are not located at all high points, the drainlayer shall install corporation cocks at such points so the air can be expelled as the line is filled with water. After all the air has been expelled, the corporation cocks shall be closed and the test pressure applied.

7.4.5 Duration of test shall not be less than two hours.

7.4.6 The test pressure shall not exceed the rated pressure of the valves in the pipeline.

7.4.7 Where leaks are visible at exposed joints and/or evident on the surface where joints are covered, the drainlayer shall repair the joints, retighten the bolts, relay the pipe, or replace the pipe until the leak is eliminated--regardless of total leakage as shown by the hydrostatic test.

7.4.8 All pipe, fittings and other materials found to be defective under test shall be removed and replaced by the Drainlayer.

7.4.9 Lines that fail to meet test requirements shall be repaired and retested as necessary until test requirements are complied with.

7.4.10 No pipe installation will be accepted if the leakage is greater than that determined by the formula:

$$L = \frac{SD(P)^{1/2}}{133,200}$$

in which L is the allowable leakage, in gallons per hour; S is the length of pipeline tested, in feet; D is the nominal diameter of the pipe, in inches; and P is the average test pressure during the leakage test, in pounds per square inch gauge.

7.5 Deflection Testing

7.5.1 Allowable Deflection Test

Pipe deflection measured not less than ninety days (90) after the backfill has been completed as specified shall not exceed five (5.0) percent. Deflection shall be computed by multiplying the amount of deflection (nominal diameter less minimum diameter when measured) by 100 and dividing by the nominal diameter of the pipe.

- 7.5.2** Deflection shall be measured with a rigid mandrel (Go/No-Go) device cylindrical in shape and constructed with a minimum of nine or ten evenly spaced arms or prongs. Drawings of the mandrel with complete dimensions shall be submitted to the Engineer for each diameter of pipe to be tested. The mandrel shall be hand pulled by the drainlayer through all sewer lines.
- 7.5.3.** Any section of sewer not passing the mandrel shall be uncovered at the Drainlayer's expense and the bedding and backfill replaced to prevent excessive deflection. Repaired pipe shall be retested.

8.0 Sewer Easements

8.1 Public Sewers

Public Sewers shall be constructed within existing public rights of way when applicable to the extent physically and legally possible. If a public sewer must be constructed within a private way or across private property, a permanent easement of no less than twenty (20) feet in width, for the construction, maintenance and operation of said public sewer, together with subordinations or releases of all mortgages and other liens on property to be made subject to the easement, shall be conveyed to the Town by appropriate persons possessing an interest in such private way or property, and accepted by the Board of Selectmen. Assertion that G.L. c.187, §5 allows for the construction and use of a public sewer within a private way as a matter of right in lieu of a record permanent easement expressly benefitting the Town of Dedham for sewer purposes is not acceptable. The cost to the Town of verifying good and clear record title and drafting or reviewing such instruments as are required to secure such title to the necessary easements (the "Title Work") shall be borne by those persons seeking construction of a public sewer on private property, who shall secure such obligation by depositing with the Town in advance of such Title Work a sum equal to its estimated cost as determined by the Town. The Town, acting by and through the Town Manager, may draw on such funds, including any interest earned, as needed to provide for the Title Work, and funds not allocated to Title Work performed shall be returned to the applicant upon request. As part of such Title Work the Town may require the applicant to provide an attorney's certification of title attesting to the grantor's ability to provide good and clear record title to the interests in land required. All sewer easements must provide reasonable and safe access for construction and vehicular maintenance equipment. No sewer will be permitted to be constructed within an easement if wetlands, uneven terrain, or other physical obstructions would limit reasonable vehicular access at any time. The Town may agree to acquire the necessary easements in a private way by the exercise of eminent domain at the applicant's sole expense, which expense shall include provision of such security as may be required in the Town's reasonable judgment to indemnify and hold harmless the Town from any and all damages, fees, and costs, including attorneys' fees, arising from such acquisition.

8.2 Private Sewers

- 8.2.1** If an individual service connection must cross someone else's property, the owner of the property being served by the sewer must obtain a construction and maintenance easement from the owner of the property that is being crossed. A permit will not be issued until the easement has been gained.
- 8.2.2** No more than one (1) building or residence will be permitted to connect into an existing private sewer easement unless the prior written approval of the Director has been obtained.
- 8.2.3** All costs for initial installation, subsequent repair, relocation, change or replacement of Building Sewers shall be at the Owner's expense.

8.3 Rules Regarding Sewer Easements

- 8.3.1** The Owner shall not place or permit to be placed any trees or other deep-rooted landscaping within the easement or directly over or within ten (10) feet horizontally of the Sewer line. Any trees or landscaping placed within the easements or rights-of-ways are at risk of being damaged or removed by the Town without the obligation of replacement.
- 8.3.2** Owner shall not place or permit to be placed any permanent or temporary structures, mounding, lighting, fencing, signs, retaining/landscaping/entrance walls, irrigation lines, etc. within the easement or directly over or ten (10) feet horizontally of Building Sewers or any other sewer facility. Any of the above listed items placed within easements or rights-of-ways are at risk of being damaged or removed by the Town without the obligation of replacement.
- 8.3.3** It shall also be the responsibility of the Owner to insure that all manhole and clean-out top of castings extend to finish grade and are not buried, sodded over, placed in concrete, or obstructed in any way.
- 8.3.4** The Town may periodically perform field inspections to verify compliance with the abovementioned requirements. If a violation exists then the Owner must immediately remedy the situation.
- 8.3.5** Bolted and gasketed sewer manhole covers will be required at all off road locations or anywhere deemed necessary by the Director.

9.0 Protection of Water Supply

9.1 Cross Connections

There shall be no physical connections between a public or private potable water supply system and a sewer or any sewer appurtenance that would permit the passage of wastewater or polluted water into the potable supply. No water pipe should pass through or come into contact with any part of a sewer manhole.

9.2 Relation to Water Main

9.2.1 Horizontal Separation

Whenever possible, sewers shall be installed at least ten (10) feet from any existing or proposed water main. If local conditions prevent a lateral separation of ten (10) feet, the Director may make an exception on a case-by-case basis when supported by data from the design engineer. Such an exception may allow the sewer to be installed closer than ten (10) feet to a water main, provided that it is laid out in a separate trench with top (crown) of the sewer at least 18 inches below the bottom (invert) of the water main.

9.2.2 Vertical Separation

Whenever sewers must cross water mains, the sewer shall be laid so that the top of the sewer is at least 18 inches below the bottom of the water main. The sewer joints should be equidistant to and located as far away as possible from the water main.

9.2.3 Concrete Encasement

When it is impossible to maintain the required separation, the sewer shall be concrete encased ten (10) feet horizontally on either side of the crossing, or continuously where there is less than ten (10) feet of separation. As an alternate, the sewer and water lines may also be constructed of mechanical joint cement lined ductile iron pipe, which shall be tested to 150 psi to assure watertightness.

9.3 Well Areas-Zone II

Any Sewers within one thousand (1,000) feet of a Public Water Supply or fifty (50) feet of a domestic well shall be of watertight construction. At a minimum, schedule 40 PVC pipe with solvent weld joints is to be used.

For all parts of new sewer connections within a designated Zone II, only hard connections will be allowed. No ferro or flexible rubber connections shall be permissible, unless approved by the Dedham Engineering Department.

9.4 Location of Sewers in Streams

9.4.1 Cover Depth

The top of all sewers entering or crossing streams should be sufficiently below the natural bottom of the streambed to protect the sewer line. In general, the following minimum cover requirements must be met:

- One (1) foot of cover where sewer is located in rock.
- Three (3) feet of cover in other material.
- One (1) foot of cover in paved stream channels.

9.4.2 Alignment

Sewers should only cross streams perpendicular to the flow without a change in grade. Sewer systems shall be designed to minimize the number of stream crossings.

10.0 Validity

All regulations or parts of regulations in conflict herewith are hereby repealed.

The invalidity of any section, clause, sentence or provision of these regulations shall not affect the validity of any other part of these Regulations, which can be given effect without such invalid part or parts.

These Sewer Regulations shall not contravene, nor render ineffective any of the lawfully established rules and regulations of the Massachusetts Department of Environmental Protection.

11.0 Appeals

The Town Manager shall receive appeals for arbitration of differences between the Director and the sewer users on matters concerning interpretation and execution of the provisions of the Regulations. The appeal must be made in writing within 10 business days of issuance.

12.0 Changes In These Regulations

These Regulations may be rescinded or modified or added to by the Town Manager at any time when, in their opinion, such action is in the best interests of the Town of Dedham, provided all provisions of the Massachusetts General Laws, as amended, have been complied with. This shall include publishing a list of proposed changes and holding a public hearing when appropriate.

13.0 Regulations In Force

13.1 These Regulations shall be in full force and effect from and after the issuance by the Town Manager and publication as provided by law.

13.2 Issued by the Town Manager of the Town of Dedham, State of Massachusetts, on the 17 day of November, 2021.

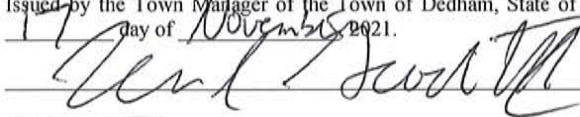

Attest:

(Town Clerk)

11/17/21
Date

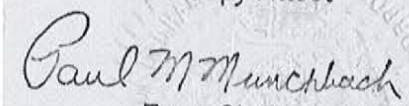
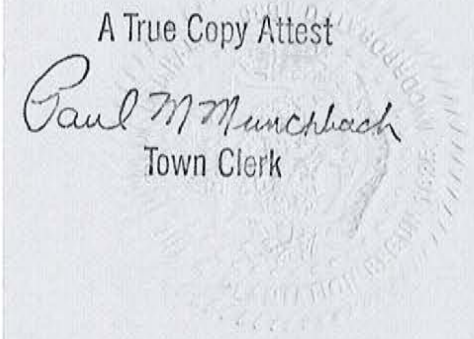
A True Copy Attest

Town Clerk

APPENDIX A

SCHEDULE OF FEES:

SEWER REPAIR PERMIT FEE: \$500.00

SEWER DISCONNECTION PERMIT FEE: \$500.00

SEWER EXTENSION PERMIT FEE: \$500.00 Plus \$2.00 per linear foot

SEWER CONNECTION PERMIT FEE: \$500.00 Plus \$7.50 per gallon per day

The Sewer Connection fee shall be calculated using the “System Sewage Flow Design Criteria” as indicated in 310 CMR 15.203. This connection fee is established to remove I/I (Inflow/Infiltration) from the Town’s sanitary sewer system based upon the amount of daily sewage flow contributing to the system from a new connection or from the increased flow in an existing connection due to additional building construction. In cases where an existing building existed on the same lot where a new building is proposed a credit for the existing flow shall be granted in accordance with section 5.4.1. The table of “Sewage Flow Estimates” is included below.

For example, a single family, three bedroom house contributes 110 gallons per day per bedroom to the Town’s sanitary sewer system. Therefore:

$$\begin{aligned} &3 \text{ bedrooms} \times 110 \text{ gallons per day} \times \$7.50 \text{ per gallon per day} = \$2,475 \\ &\$2,475 + \$500 = \$2,975 \text{ (Total Sewer Connection Fee)} \end{aligned}$$

****All permit fees are due at the time of application.****



**APPLICATION FOR DRAINLAYER'S LICENSE
TOWN OF DEDHAM
DEDHAM, MASSACHUSETTS 02026**

OFFICE USE ONLY:

LICENSE NUMBER: _____

APPLICATION RECEIVED: _____

ENGINEERING APPROVAL: _____

BY: _____

SELECTMEN APPROVAL: _____

Application Type: New License License Renewal If Renewal, list
previous License # _____

Name of Corporation: _____

Contact Person: _____

Mailing Address: _____

Street Address: _____

Phone: _____

FAX: _____

24-Hour Phone: _____

The Following items must be attached:

- A copy of Valid Heavy Equipment Operators License
- Insurance Certificate (Town must be listed as additionally insured)
- Performance Bond (USE ATTACHED FORM)
- Three (3) references who are familiar with your work with telephone numbers (NOT REQUIRED FOR RENEWALS)
- License fee of \$250.00

**THE UNDERSIGNED HEREBY ACKNOWLEDGES RECEIPT AND
UNDERSTANDING OF THE SEWER REGULATIONS, AND THAT HE/SHE HAS
READ THE ENTIRE DOCUMENT.**

Signature: _____ Date: _____

Bond Number: _____

PERFORMANCE BOND

KNOW ALL MEN BY THESE PRESENTS:

That we, _____ (an individual, partnership, corporation or company) duly organized under the Laws of the State of Massachusetts, and having a usual place of business at:

_____ as Principal, and

_____ a corporation duly organized under the Laws of

the State of _____ and duly authorized to do business in the Commonwealth of

Massachusetts, and having a usual place of business at _____ as Surety, are holden and stand firmly bond and obligated unto the Town of Dedham, Massachusetts, as obligee, in the sum of **Five Thousand Dollars and no/cents (\$5,000.00)** lawful money of the United States of America, to and for the true payments whereof we bind ourselves and, each of us, our heirs, executors, administrators, successors, and assigns, jointly and severally, firmly by these presents.

WHEREAS, the Principal, by means of a written AGREEMENT (current revision of the Town of Dedham Sewer Regulations) shall install drains and sewers in the Town of Dedham in accordance with the regulations.

Whenever the Company shall be, and declared by the Town to be in default under the Sewer Regulations shall promptly remedy the default or complete the drain and sewer work.

No right of action shall accrue on the Bond to or for the use of any persons other than the Town named herein or the heirs, executors, administrators, successors and assigns of the Town.

IN WITNESS WHEREOF, we have hereunto set our hands and seals this day _____ of _____.

Principal: _____

Surety: _____

(SEAL)

By: _____

By: _____

(SEAL)

Title: _____

Title: _____

IMPORTANT

Surety Companies executing BONDS must appear on the U.S. Treasury Department's most current list of "Companies Holding Certificates of Authority as Acceptable Sureties on Federal Bonds and as Acceptable Reinsuring Companies" as published in Circular 570 (amended) by the Audit Staff Bureau of Accounts and be authorized to transact business in the State of Massachusetts.

The attention of the Surety Companies and Company executing this Performance Bond is directed to the fact that said Bond shall remain in full effect for a period of two (2) years from the effective date of the issuance of a Drainlayer's License.

APPENDIX C

SEWAGE FLOW ESTIMATES:

Type of Establishment (Unit)	Gallons Per Day
RESIDENTIAL:	
Bed & Breakfast (per bedroom)	110
Bed & Breakfast with restaurant open to public	110 per bedroom + 35 per seat
Camp, resident, mess hall, washroom and toilets (per person)	35
Camp, day, washroom and toilets (per person)	10
Camp, day, mess hall, washroom and toilets (per person)	13
Campground, showers and toilets (per site)	90
Family Dwelling, Single (per bedroom)	110
Family Dwelling, Multiple (per bedroom)	110
Family Mobile Home Park (per mobile home)	300
Motel, Hotel, Boarding House (per bedroom)	110
Retirement Mobile Home Park (per site)	150
Housing for the Elderly (per two bedroom unit) *	150
Work or Construction Camp (per person)	50
COMMERCIAL:	
Airport (per passenger)	5
Barber Shop/Beauty Salon (per chair)	100
Bowling Alley (per alley)	100
Country Club, dining room (per seat)	10
Country Club, snack bar or lunch room (per seat)	10
Country Club, locker and showers (per locker)	20
Doctor Office (per doctor)	250
Dentist Office (per dentist)	200
Factory, Industrial Plant, Warehouse or Dry Storage Space without cafeteria (per person)	15
Factory, Industrial Plant, Warehouse or Dry Storage Space with cafeteria (per person)	20
Gasoline Station (per island)	75
Gasoline Station with Service Bays	75 per island +125 per bay
Kennel/Veterinary Office (per kennel)	50

TOWN OF DEDHAM
SEWER REGULATIONS

Type of Establishment (Unit)	Gallons Per Day
Lounge, Tavern (per seat)	20
Marina (per slip)	10
Movie Theater (per seat)	5
Non-single family/automatic clothes washer (per washing machine)	400
Office Building (per 1,000 sq. ft.)	75
Retail Store, except supermarkets (per 1,000 sq. ft.)	50
Restaurant (per seat)	35
Restaurant, thruway service area (per seat)	150
Restaurant, Fast Food (per seat)	20
Restaurant, kitchen flow for grease trap sizing only (per seat)	15
Service Station, no gas (per bay)	150
Skating Rink (per seat)	5
Supermarkets (per 1,000 sq. ft.)	97
Swimming Pool (per person)	10
Tennis Club (per court)	250
Theater, Auditorium (per seat)	3
Trailer, dump station (per trailer)	75
INSTITUTIONAL:	
Place of worship without kitchen (per seat)	3
Place of worship with kitchen (per seat)	6
Correctional Facility (per bed)	200
Function Hall (per seat)	15
Gymnasium (per participant)	25
Gymnasium (per spectator)	3
Hospital (per bed)	200
Nursing Home/Rest Home (per bed)	150
Public Park, toilet waste only (per person)	5
Public Park, bathhouse, showers and flush toilets (per person)	10
Day Care Facility (per person)	10
SCHOOLS:	
Elementary School, without cafeteria, gymnasium or showers (per person)	5
Elementary School, with cafeteria but no gymnasium with showers (per person)	8
Elementary School, with cafeteria, gymnasium and showers (per person)	10
Secondary/Middle School, without cafeteria, gymnasium or showers (per person)	10

TOWN OF DEDHAM
SEWER REGULATIONS

Type of Establishment (Unit)	Gallons Per Day
Secondary/Middle School, with cafeteria but no gymnasium or showers (per person)	15
Secondary/Middle School, with cafeteria, gymnasium and showers (per person)	20
Boarding Schools, Colleges (per person)	65

For purposes of 310 CMR 15.203, a "bedroom" means any portion of a dwelling which is so designed as to furnish the minimum isolation necessary for use as a sleeping area. Such area shall not include kitchen, bathroom, dining room, halls, or unfinished cellar; but may include bedroom, den, study, sewing room, or sleeping loft.

APPENDIX D

SEWER CONSTRUCTION DETAILS

SANITARY SEWER

<u>DESCRIPTION</u>	<u>DETAIL NUMBER</u>
GENERAL NOTES FOR PIPE TRENCHES	SS.01
TRENCH SECTION FOR SEWER PIPE (18-INCH DIAMETER AND SMALLER)	SS.02
TRENCH SECTION IN UNSUITABLE MATERIAL	SS.03
MANHOLE RISER WITH ECCENTRIC CONE TOP	SS.04
PRECAST REINFORCED CONCRETE MANHOLE BASE FOR SEWERS	SS.05
MANHOLE FRAME & COVER MARKED "SEWER"	SS.06
WATERTIGHT RESILIENT CONNECTOR FOR CONNECTING PIPES TO PRECAST CONCRETE MANHOLES	SS.07
NON-SHRINK MORTAR JOINTS FOR CONNECTING PIPES TO BRICK OR BLOCK MASONRY MANHOLES	SS.08
PRECAST REINFORCED CONCRETE SEWER CHIMNEY	SS.09
TYPICAL SONOTUBE CAST-IN-PLACE SEWER CHIMNEY	SS.10
RECONSTRUCTED BUILDING CONNECTION	SS.11
ABANDON EXISTING MANHOLES/CESSPOOLS	SS.12
TYPICAL SEWER CLEANOUT DETAIL	SS.13
SEWER CLEANOUT DETAIL WITHIN 10' OF BUILDING FOUNDATION	SS.14



**DEDHAM DPW
DESIGN & CONSTRUCTION STANDARDS**

DETAIL INDEX
SANITARY SEWER

SCALE: NTS	DATE OF ISSUE: AUGUST 2015
---------------	-------------------------------

REVISED:

DETAIL NUMBER: SS—INDEX.01

SANITARY SEWER CONTINUED

<u>DESCRIPTION</u>	<u>DETAIL NUMBER</u>
TYPICAL OUTSIDE DROP MANHOLE DETAIL	SS.15
INSIDE DROP INLETS FOR PVC PIPE SEWERS (12-INCH DIAMETER AND SMALLER)	SS.16
PIPE TRENCH DAM DETAIL	SS.17
WYE-SADDLE DETAIL FOR SERVICE CONNECTION ON R.C. OR V.C. MAIN	SS.18
P.V.C. WYE INSERTED ON EXISTING MAIN	SS.19
TYPICAL UTILITY CROSSINGS	SS.20
SANITARY SEWER PROTECTION DURING SEWER EXTENSION CONSTRUCTION	SS.21
FORCE MAIN CLEANOUT MANHOLE DETAIL	SS.22
LOW PRESSURE SEWER SERVICE VALVE BOX	SS.23
THRUST BLOCKS	SS.24
COMBINATION AIR RELEASE VALVE	SS.25
HIGH VELOCITY MANHOLE INVERT	SS.26
STANDARD GREASE TRAP	SS.27
TYPICAL SEWER PLAN	SS.28
TYPICAL SEWER PROFILE	SS.29



DEDHAM DPW DESIGN & CONSTRUCTION STANDARDS

DETAIL INDEX
SANITARY SEWER

SCALE: NTS	DATE OF ISSUE: AUGUST 2015
---------------	-------------------------------

REVISED:

DETAIL NUMBER: SS-INDEX.02

GENERAL NOTES FOR PIPE TRENCHES

1. PIPE TRENCHES MAY BE EXCAVATED WIDER THAN TRENCH WIDTH W_s (SHEETED) OR W_u (UNSHEETED) ABOVE THE TOP OF PIPE ZONE.
2. TRENCHES SHALL NOT BE EXCAVATED BEYOND THE TRENCH WIDTH W_u BELOW THE TOP OF PIPE ZONE.
3. SHEETING MUST BE USED IF EXCAVATION AND BACKFILL, BELOW NORMAL DEPTH, IS REQUIRED. SHEETING SHALL BE LEFT IN PLACE AS SPECIFIED.
4. ALL ROCK WITHIN 3'-0" HORIZONTALLY OF THE ENDS OF BUILDING CONNECTIONS, BRANCHES OR STUBS AND DOWN TO A HORIZONTAL PLANE 6" BELOW THE BOTTOMS OF SUCH CONNECTIONS, BRANCHES OR STUBS, SHALL BE EXCAVATED.
5. WHERE INDICATED ON THE DRAWINGS, GEOTEXTILE FILTER FABRIC SHALL BE PROVIDED FOR SEWER AND BUILDING CONNECTION FOUNDATIONS. OVERLAP FABRIC ABOVE THE PIPE CROWN AND PROVIDE A MINIMUM OF 12" FABRIC OVERLAP.

TRENCH WIDTH W_s OR W_u		
NOMINAL PIPE DIAMETER D	DEPTH OF PIPE INVERT BELOW GROUND SURFACE	
	0 TO 12'	12' TO 20'
24" AND SMALLER	5'-0"	7'-0"
OVER 24"	$D + 3'-0"$	$D + 5'-0"$



DEDHAM DPW DESIGN & CONSTRUCTION STANDARDS

GENERAL NOTES FOR PIPE TRENCHES

SCALE: NTS	DATE OF ISSUE: AUGUST 2015
---------------	-------------------------------

REVISED:

DETAIL NUMBER: SS.01

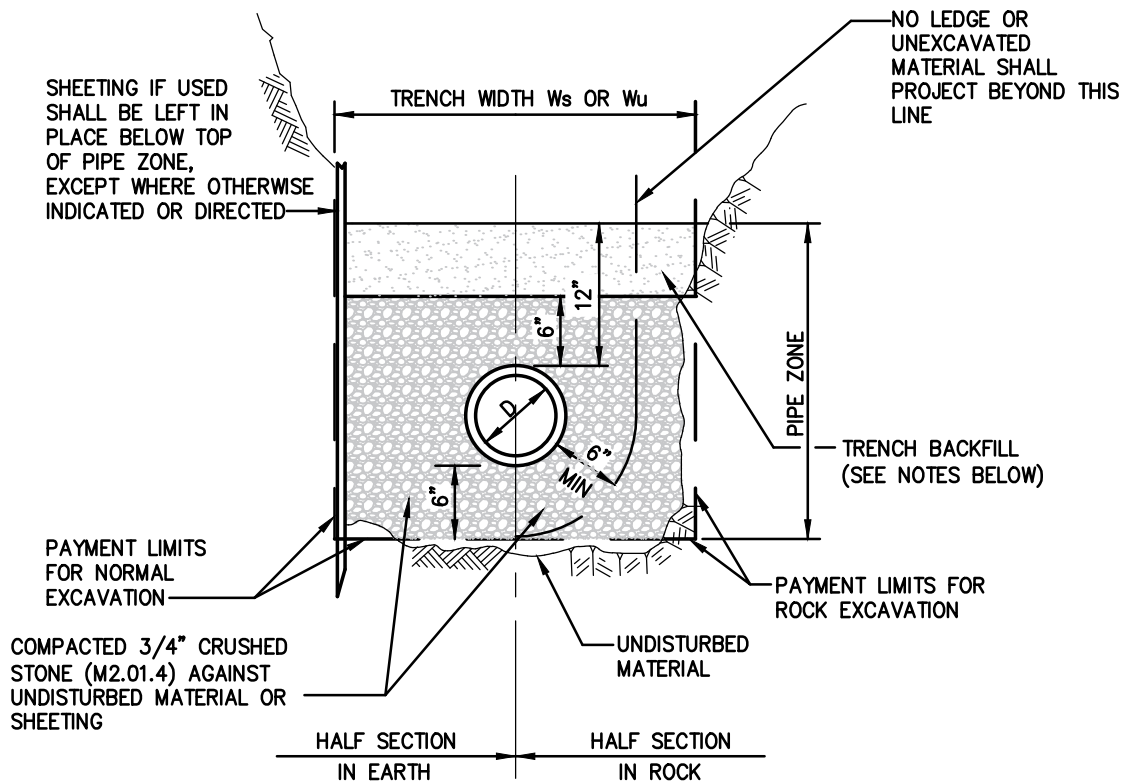

NOTES:

1. TRENCH BACKFILL TO BE USED WITHIN THE RIGHT-OF-WAY SHALL CONSIST OF EITHER GRAVEL BORROW MEETING MassDOT SPECIFICATION M1.03.0, TYPE "B" OR PROCESSED GRAVEL BORROW FOR SUBBASE MEETING MassDOT SPECIFICATION M1.03.1.
2. WHERE THE REMOVAL OF 100 SQUARE FEET OR LESS OF ASPHALT IS REQUIRED WITHIN THE RIGHT-OF-WAY, THEN THE TRENCH BACKFILL MATERIAL SHALL CONSIST OF CONTROLLED DENSITY FILL MEETING MassDOT SPECIFICATION M4.08.0, TYPE "1E" OR "2E".
3. TRENCH BACKFILL MATERIAL TO BE USED OUTSIDE OF THE RIGHT-OF-WAY MAY CONSIST OF MATERIAL GENERATED DURING EXCAVATIONS PROVIDED ALL STONES GREATER THAN 4" ARE REMOVED PRIOR TO PLACEMENT AND COMPACTION.
4. GRANULAR TRENCH BACKFILL MATERIAL USED WITHIN THE RIGHT-OF-WAY SHALL BE PLACED IN MAXIMUM 6" LIFTS AND MECHANICALLY COMPACTIONED TO A MINIMUM OF 95% OF THE MATERIAL'S MAXIMUM DRY DENSITY AND TO 90% ELSEWHERE AS DETERMINED BY ASTM D 1557.
5. REFER TO DETAILS RS.33-RS.35 FOR ASPHALT REPAIR REQUIREMENTS.



**DEDHAM DPW
DESIGN & CONSTRUCTION STANDARDS**

TRENCH SECTION FOR SEWER PIPE
18-INCH DIAMETER AND SMALLER

SCALE: NTS	DATE OF ISSUE: AUGUST 2015
REVISED:	
DETAIL NUMBER: SS.02	

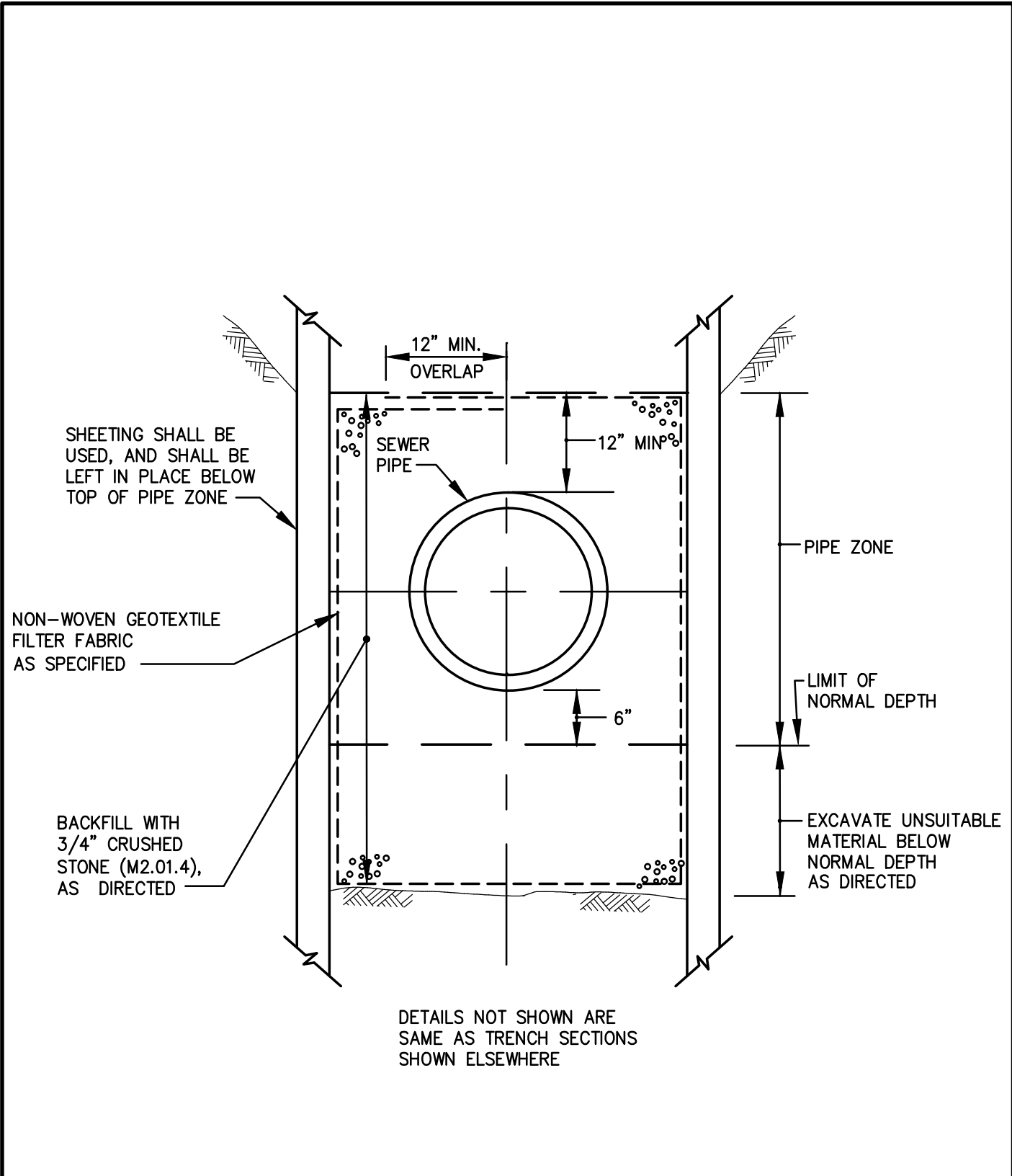

**DEDHAM DPW
DESIGN & CONSTRUCTION STANDARDS**

TRENCH SECTION IN UNSUITABLE MATERIAL

SCALE: NTS	DATE OF ISSUE: AUGUST 2015
REVISED:	
DETAIL NUMBER: SS.03	

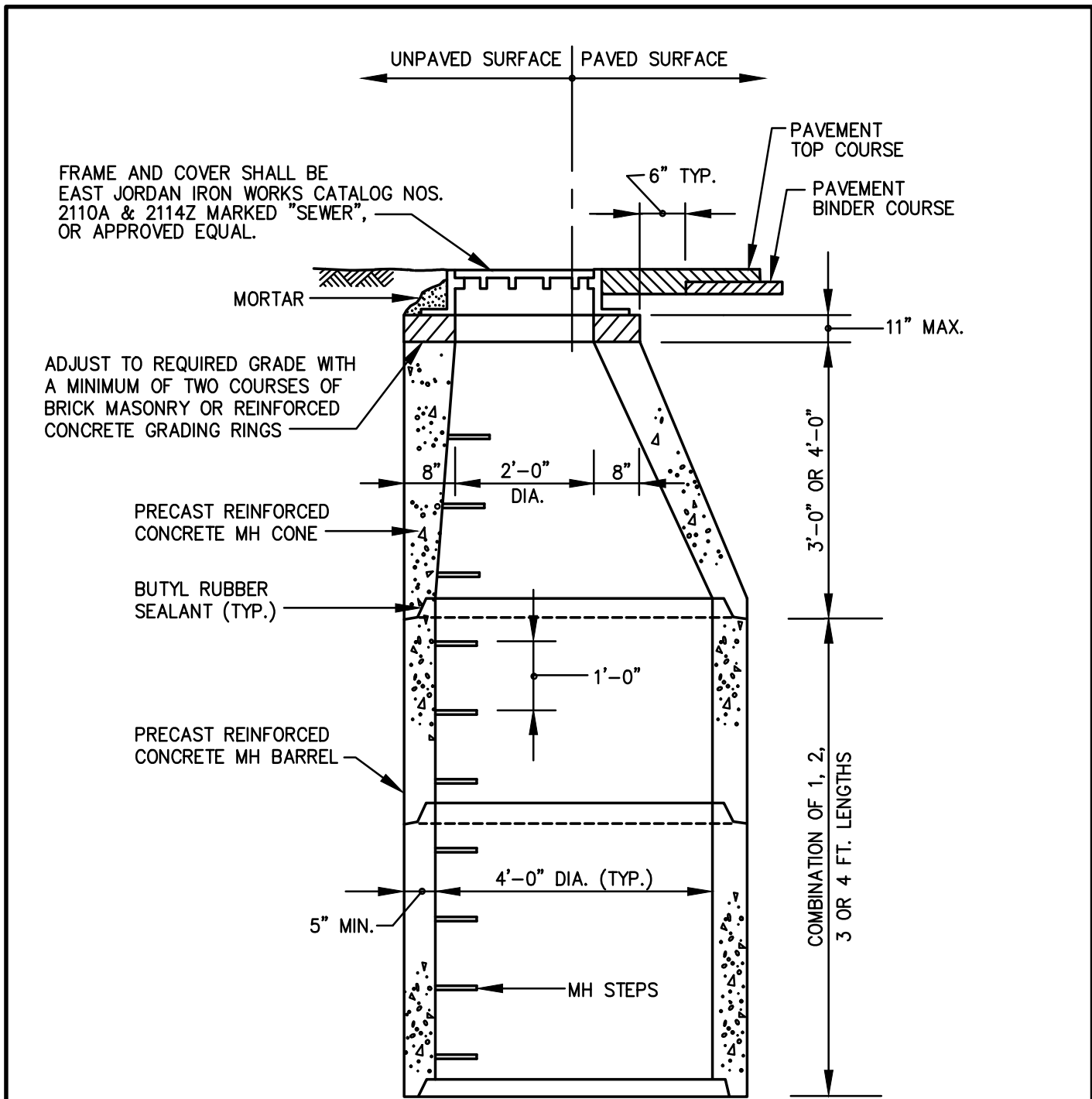

NOTE:
 ALL EXTERIOR SURFACES OF MANHOLE GRADE ADJUSTMENT COURSES SHALL BE COVERED WITH 1/4" TO 3/8" MASONRY CEMENT PLASTER.



**DEDHAM DPW
 DESIGN & CONSTRUCTION STANDARDS**

MANHOLE RISER WITH ECCENTRIC CONE TOP

SCALE: NTS	DATE OF ISSUE: AUGUST 2015
REVISED:	
DETAIL NUMBER: SS.04	

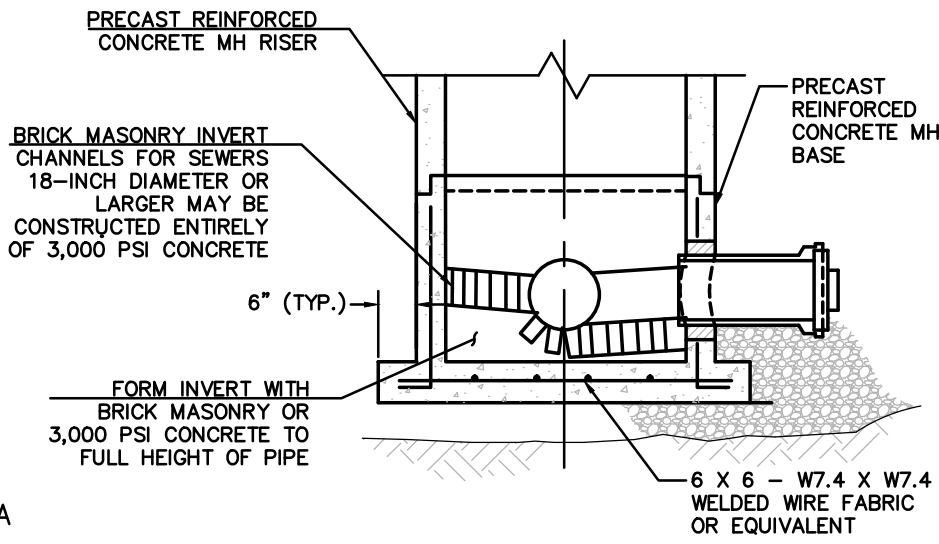

SECTION A-A

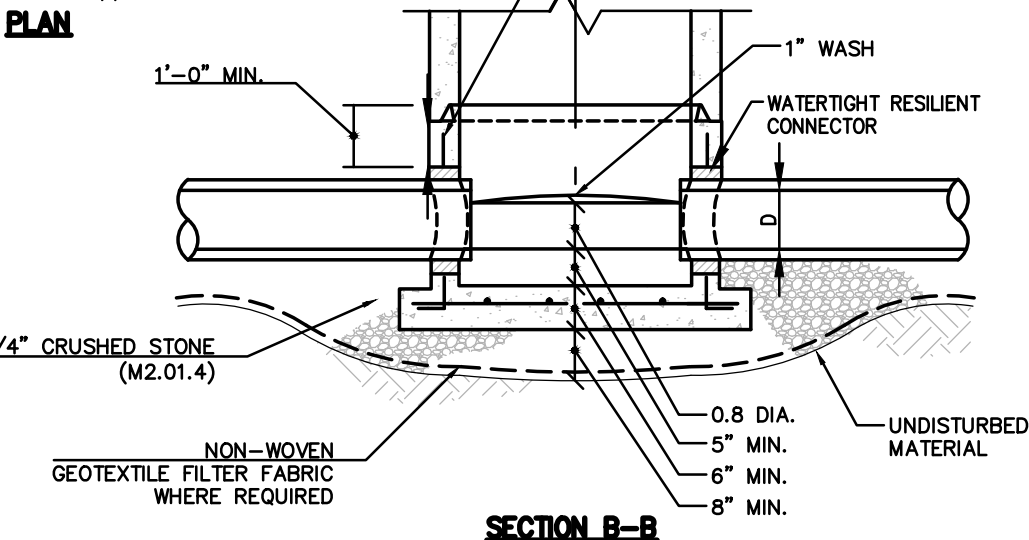
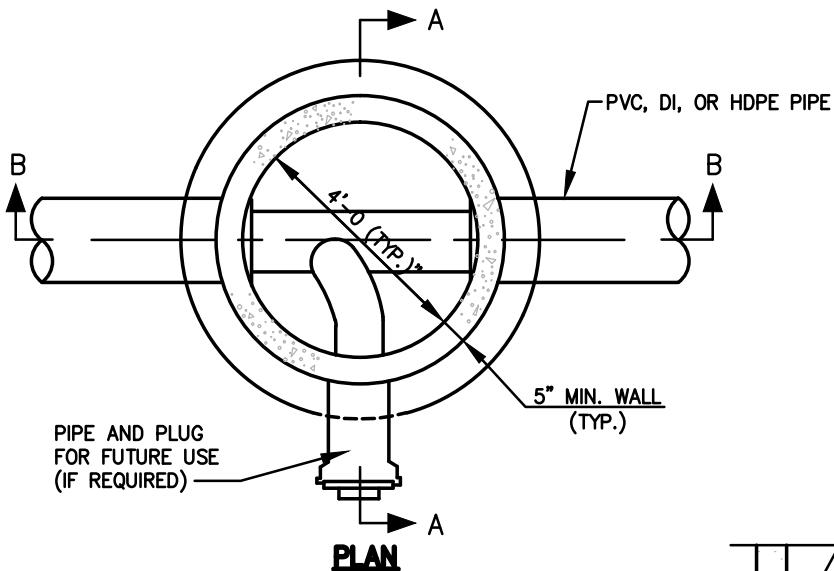

SECTION B-B



**DEDHAM DPW
DESIGN & CONSTRUCTION STANDARDS**

PRECAST REINFORCED CONCRETE
MANHOLE BASE FOR SEWERS

SCALE: NTS	DATE OF ISSUE: AUGUST 2015
REVISED:	
DETAIL NUMBER: SS.05	

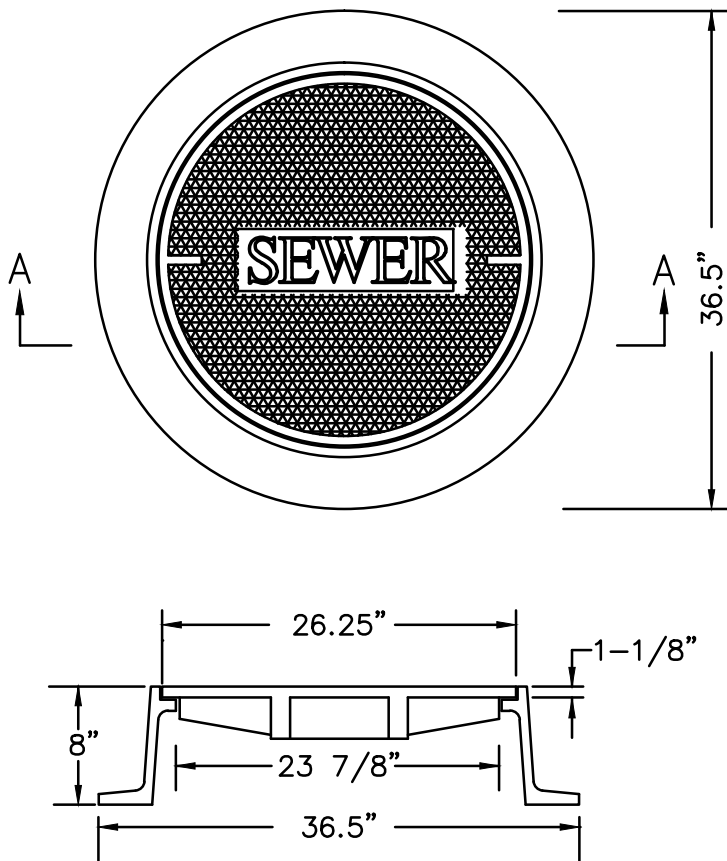

SECTION A-A

NOTE:

FRAME AND COVER SHALL BE EAST JORDAN IRON WORKS CATALOG NOS. 2110A & 2114Z MARKED "SEWER", OR APPROVED EQUAL.



**DEDHAM DPW
DESIGN & CONSTRUCTION STANDARDS**

MANHOLE FRAME & COVER
MARKED "SEWER"

SCALE: NTS	DATE OF ISSUE: AUGUST 2015
---------------	-------------------------------

REVISED:

DETAIL NUMBER: SS.06

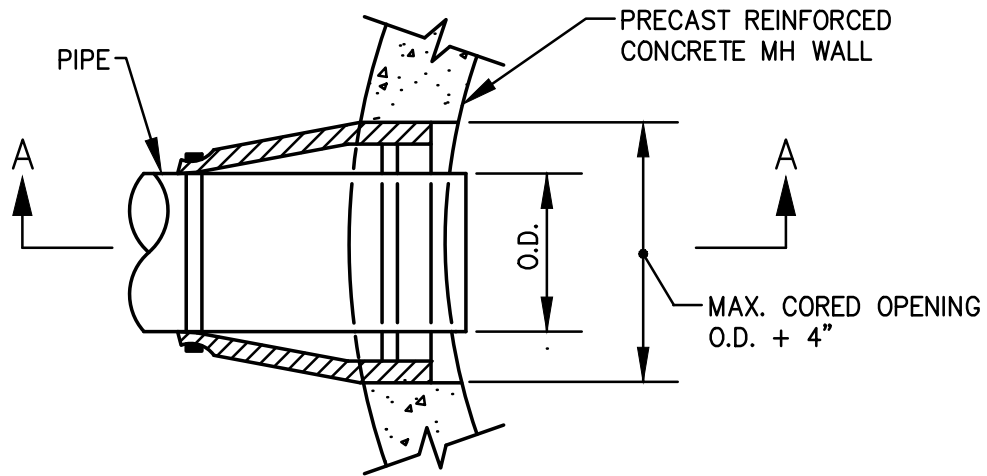

PLAN

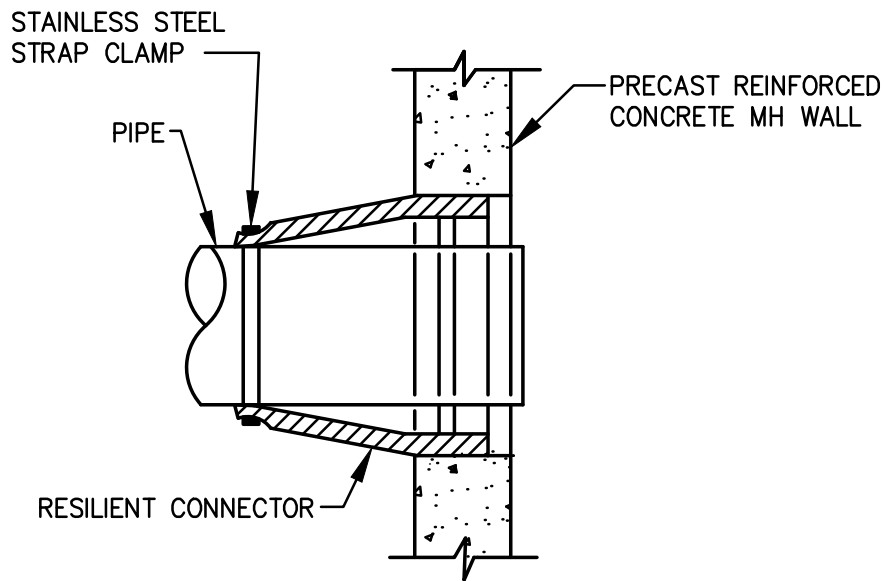

SECTION A-A



**DEDHAM DPW
DESIGN & CONSTRUCTION STANDARDS**

**WATERTIGHT RESILIENT CONNECTOR FOR CONNECTING
PIPES TO PRECAST CONCRETE MANHOLES**

SCALE: NTS	DATE OF ISSUE: AUGUST 2015
---------------	-------------------------------

REVISED:

DETAIL NUMBER: SS.07

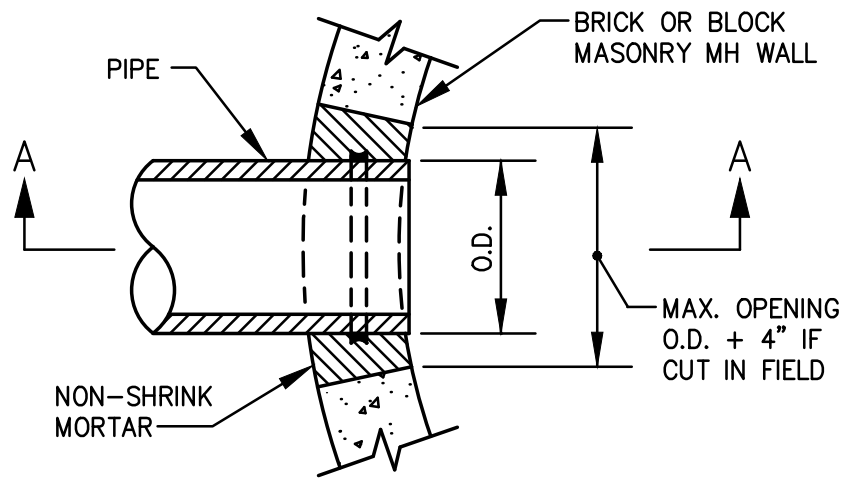

PLAN

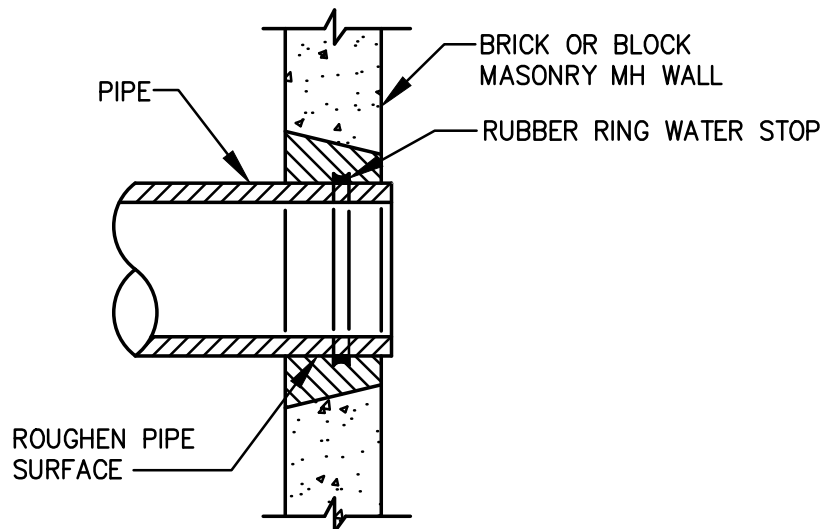

SECTION A-A

NOTES:

1. THIS METHOD ONLY TO BE USED UNDER SPECIAL CIRCUMSTANCES AND WITH PRIOR APPROVAL FROM THE DIRECTOR OF ENGINEERING. THE WATERTIGHT RESILIENT CONNECTOR IS THE PREFERRED CONNECTION METHOD.



**DEDHAM DPW
DESIGN & CONSTRUCTION STANDARDS**

NON-SHRINK MORTAR JOINTS FOR CONNECTING
PIPES TO BRICK OR BLOCK MASONRY MANHOLES

SCALE: DATE OF ISSUE:
NTS AUGUST 2015

REVISED:

DETAIL NUMBER:
SS.08

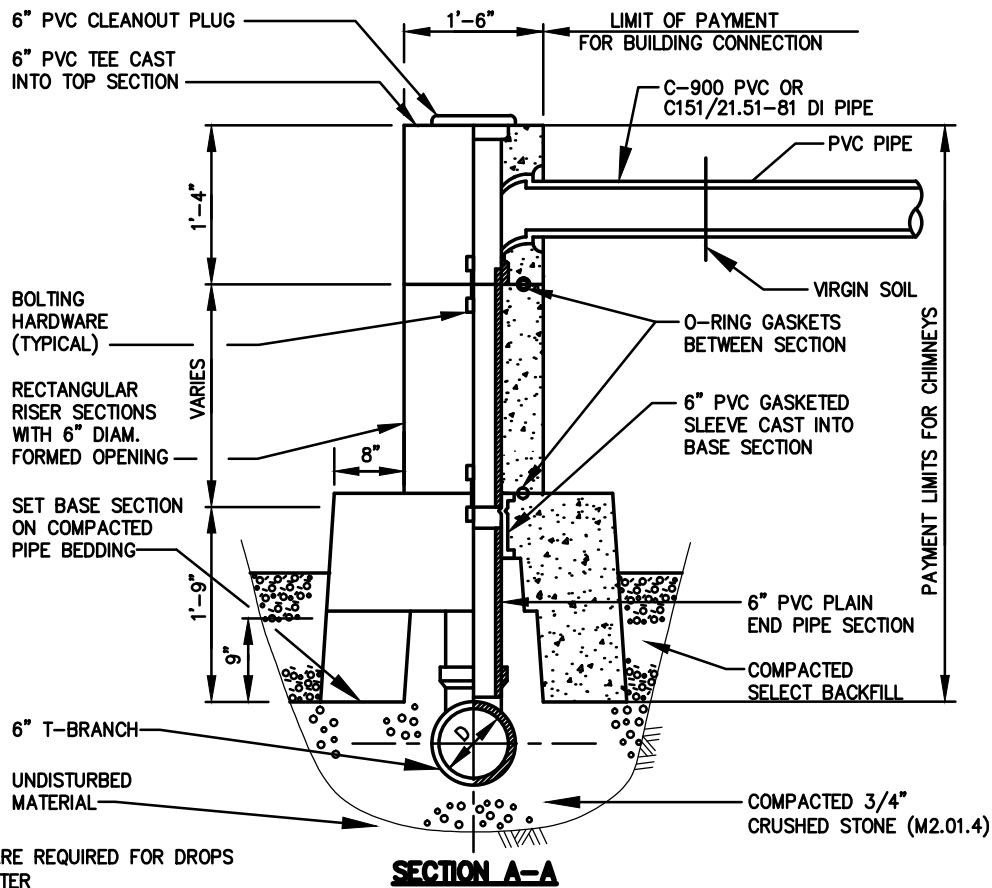
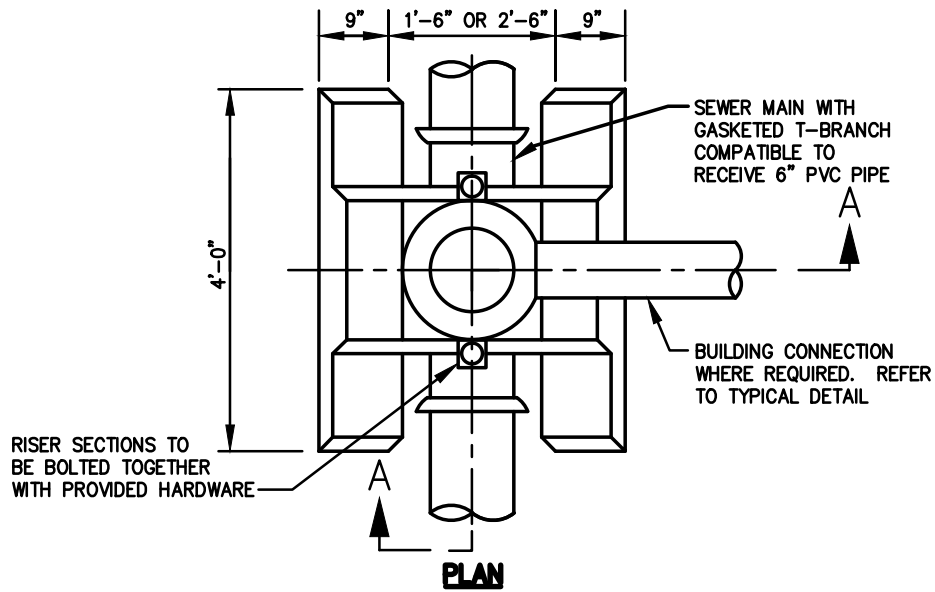

* CHIMNEYS ARE REQUIRED FOR DROPS 3' OR GREATER



**DEDHAM DPW
DESIGN & CONSTRUCTION STANDARDS**

PRECAST REINFORCED CONCRETE SEWER CHIMNEY

SCALE: DATE OF ISSUE:
NTS AUGUST 2015

REVISED:

DETAIL NUMBER:
SS.09

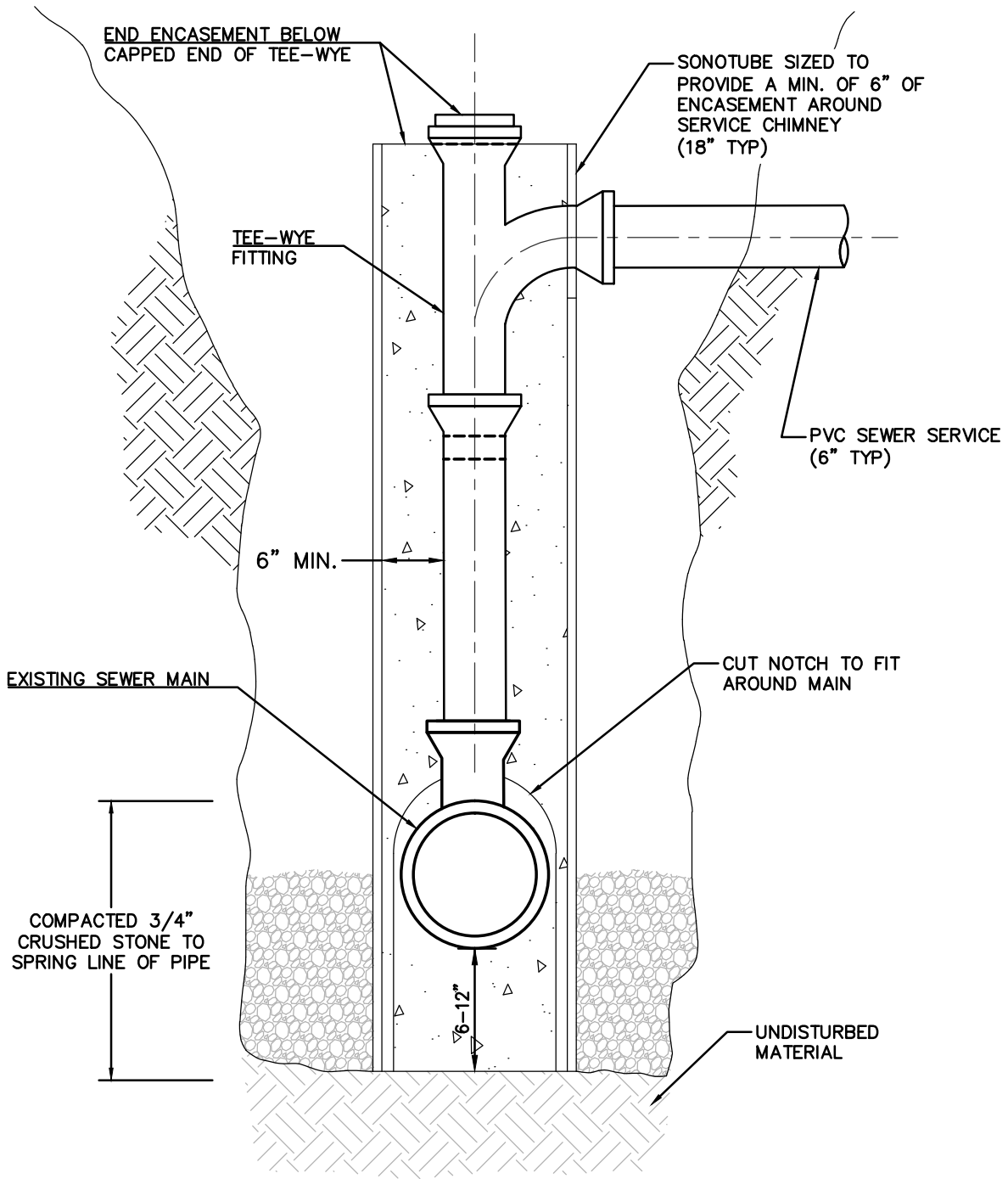

* CHIMNEYS ARE REQUIRED FOR DROPS 3' OR GREATER



**DEDHAM DPW
DESIGN & CONSTRUCTION STANDARDS**

TYPICAL SONOTUBE
CAST-IN-PLACE SEWER CHIMNEY

SCALE: NTS	DATE OF ISSUE: AUGUST 2015
---------------	-------------------------------

REVISED:

DETAIL NUMBER: SS.10

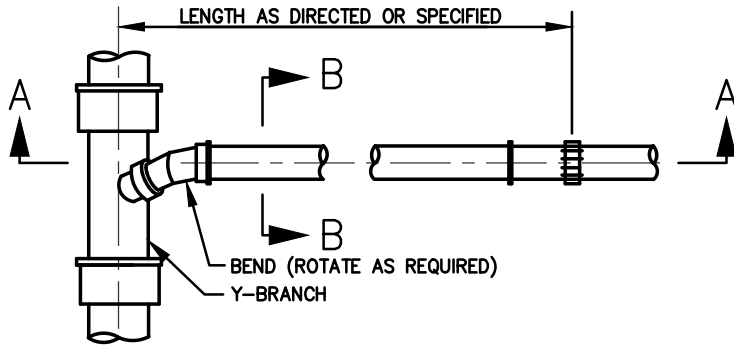

PLAN

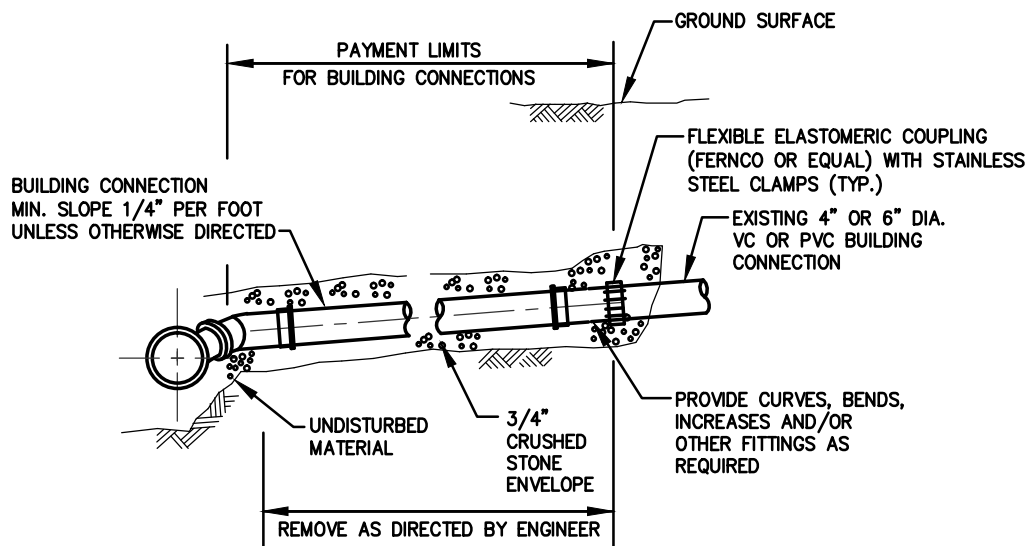

SECTION A-A

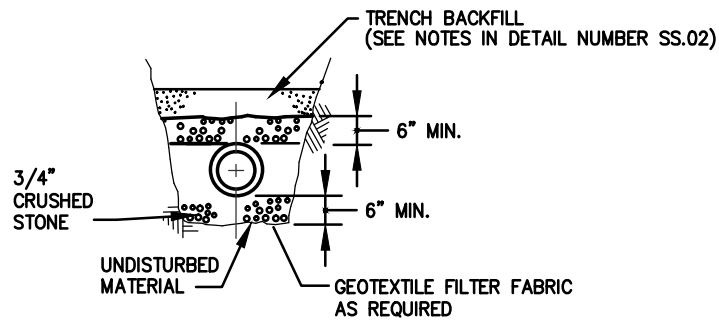

SECTION B-B



**DEDHAM DPW
DESIGN & CONSTRUCTION STANDARDS**

RECONSTRUCTED BUILDING CONNECTION

SCALE: NTS DATE OF ISSUE:
AUGUST 2015

REVISED:

DETAIL NUMBER:
SS.11

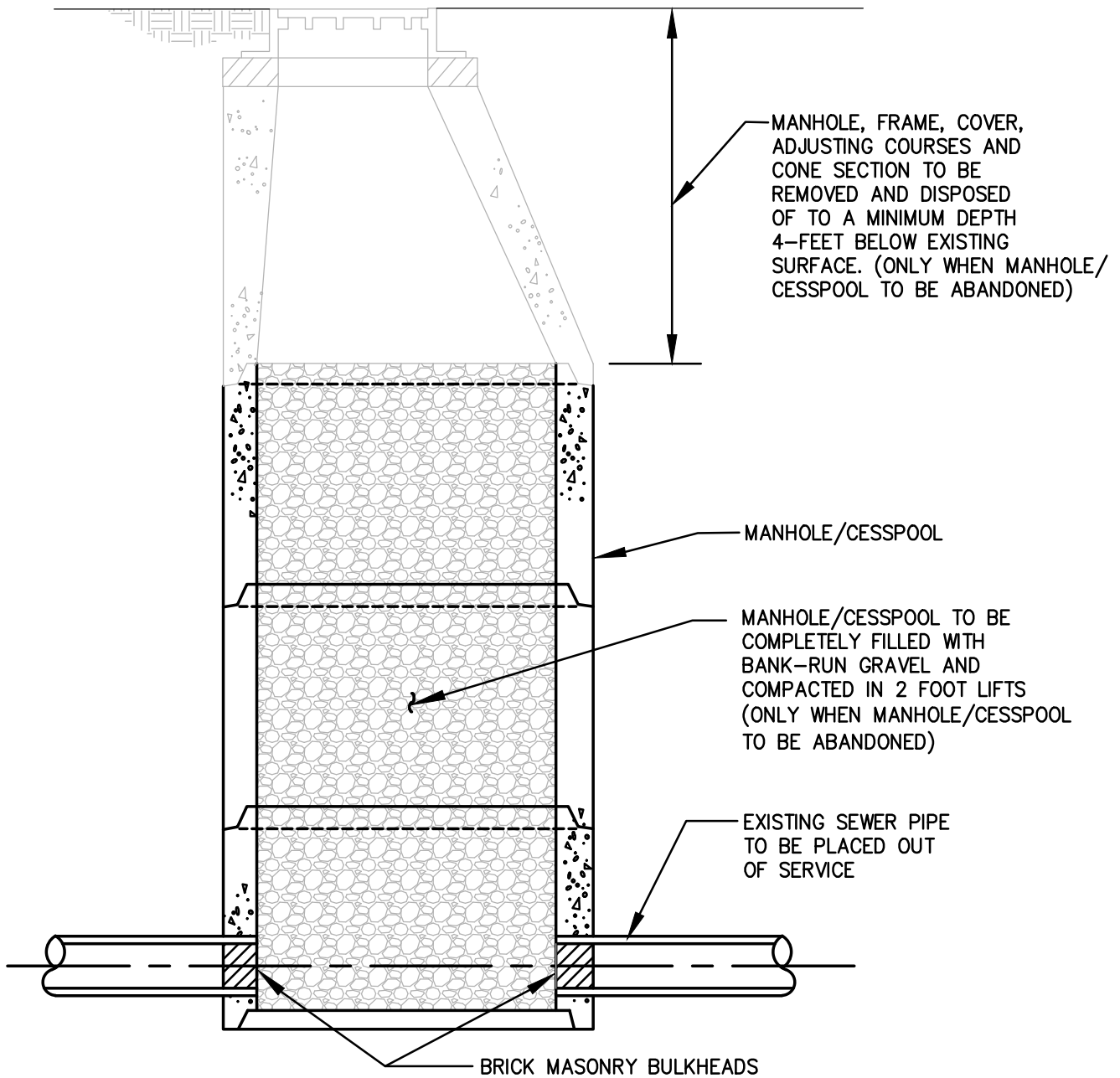

**DEDHAM DPW
DESIGN & CONSTRUCTION STANDARDS**

ABANDON EXISTING MANHOLES/CESSPOOLS

SCALE: NTS	DATE OF ISSUE: AUGUST 2015
---------------	-------------------------------

REVISED:

DETAIL NUMBER: SS.12

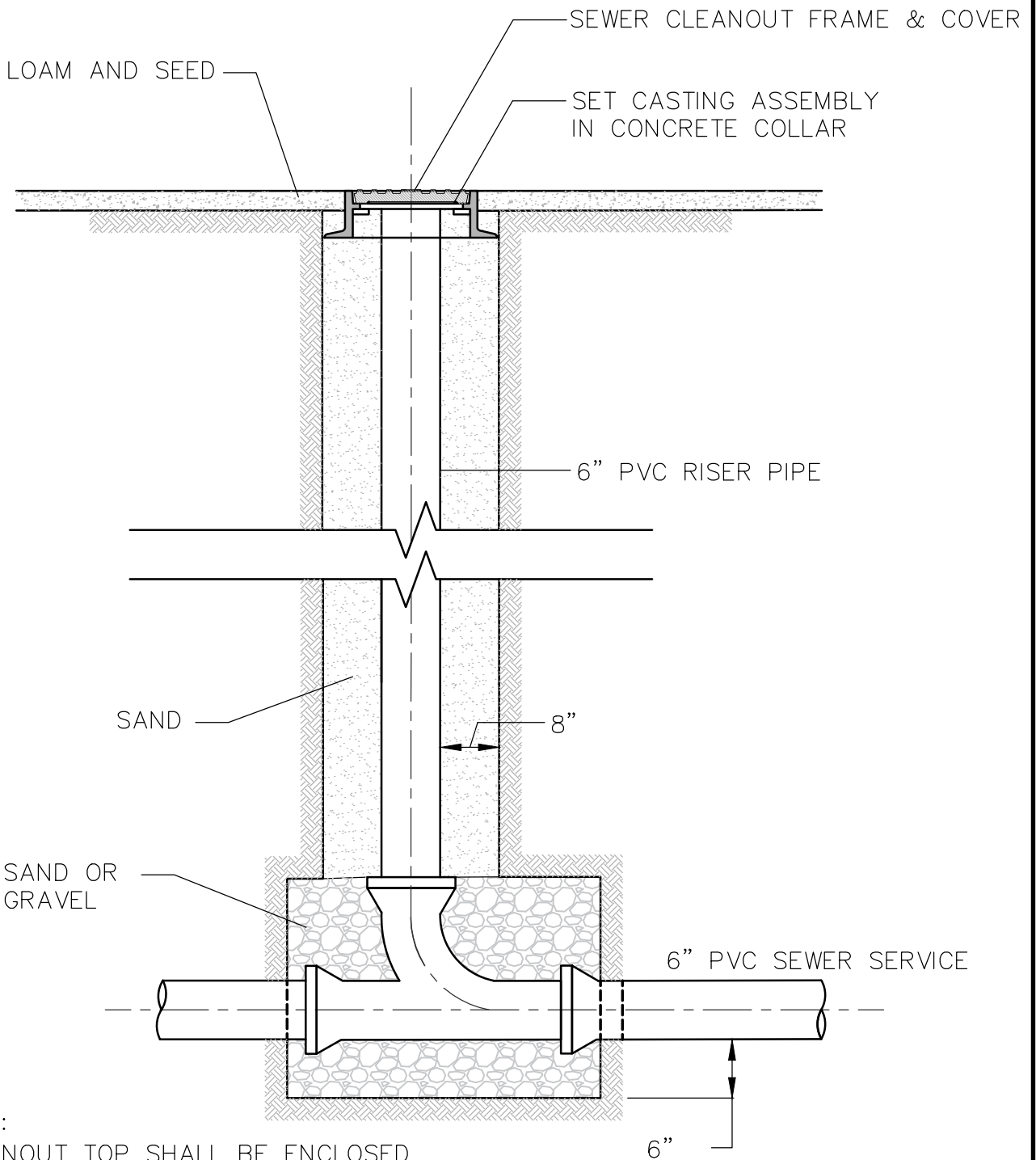

**DEDHAM DPW
DESIGN & CONSTRUCTION STANDARDS**

TYPICAL SEWER CLEANOUT DETAIL

SCALE: DATE OF ISSUE:
NTS AUGUST 2015

REVISED:

DETAIL NUMBER:
SS.13

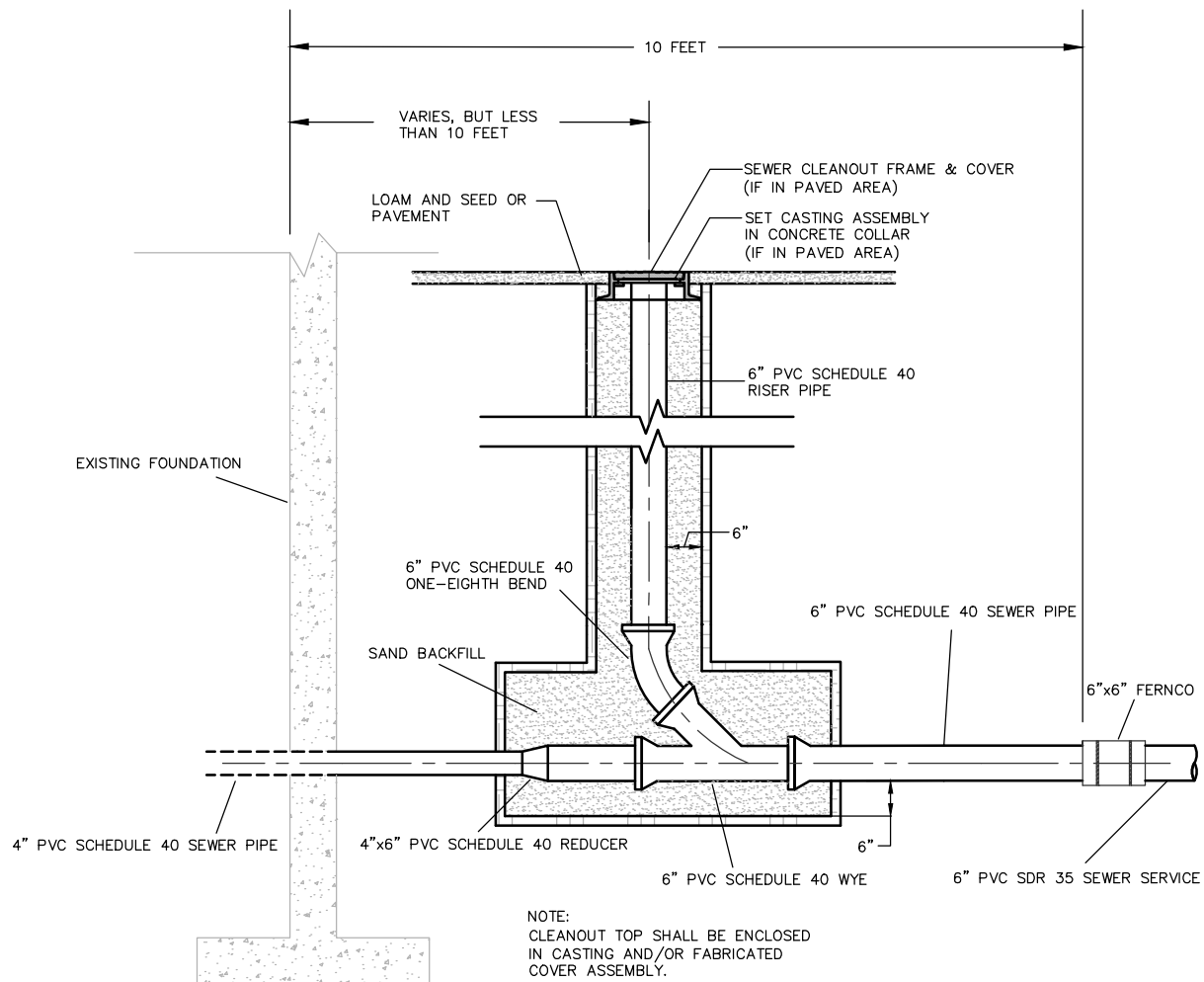

NOTES:

- SEWER CLEANOUTS SHALL TYPICALLY BE LOCATED A MINIMUM OF 10' FROM THE FOUNDATION. HOWEVER, IN SPECIAL CIRCUMSTANCES THE CLEANOUT MAY BE LOCATED WITHIN 10' OF THE FOUNDATION WITH PERMISSION FROM THE ENGINEERING DEPARTMENT. THE 10' ZONE SHALL BE CONSIDERED THE DISTANCE FROM THE INSIDE FACE OF THE FOUNDATION TO A DISTANCE OF 10' OUTSIDE OF THE FOUNDATION, PERPENDICULAR TO THE INSIDE FACE OF THE FOUNDATION.
- ALL WORK TO BE CONDUCTED WITHIN THE 10' ZONE SHALL BE PERFORMED BY A PLUMBER LICENSED IN THE STATE OF MASSACHUSETTS AND SHALL CONFORM TO 248 CMR 2.00 AND 248 CMR 10.00.



**DEDHAM DPW
DESIGN & CONSTRUCTION STANDARDS**

**SEWER CLEANOUT DETAIL WITHIN
10' OF BUILDING FOUNDATION**

SCALE: NTS	DATE OF ISSUE: AUGUST 2015
REVISED:	
DETAIL NUMBER: SS.14	

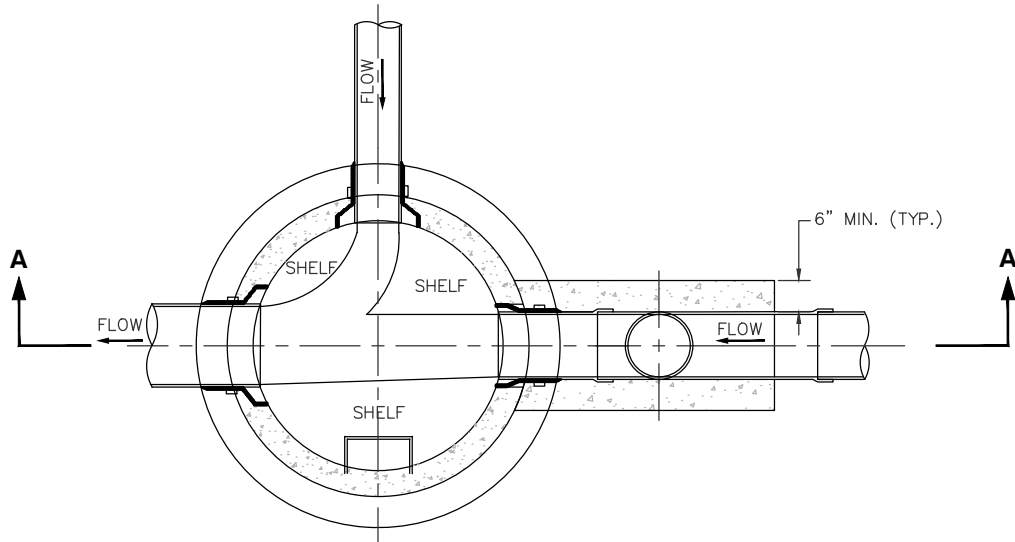

PLAN

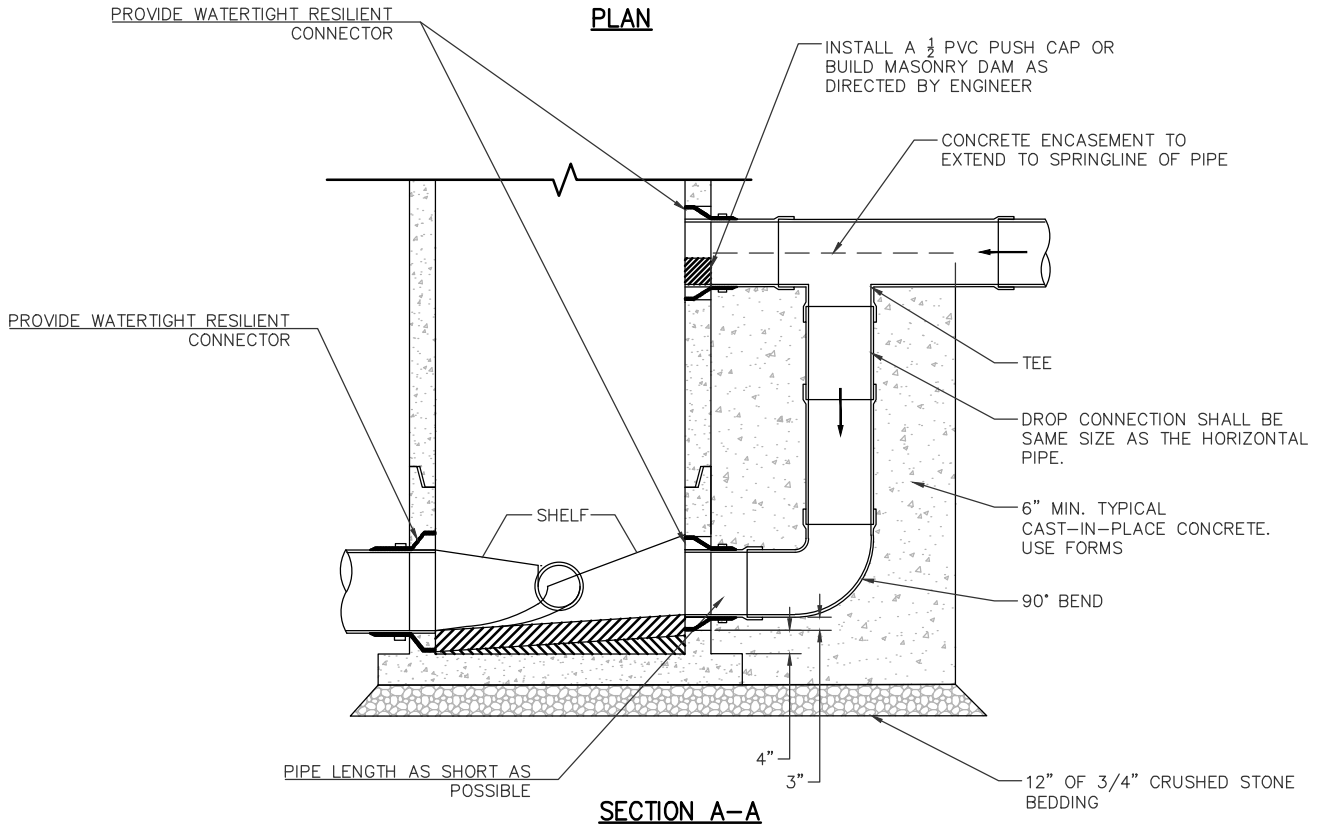

SECTION A-A

NOTES:

1. DROP MANHOLES ARE REQUIRED WHEN THE VERTICAL DROP IS 24" OR GREATER.
2. DROP PIPE AND FITTINGS SHALL BE THE SAME DIAMETER AS THE INCOMING SEWER PIPE.



**DEDHAM DPW
DESIGN & CONSTRUCTION STANDARDS**

TYPICAL OUTSIDE DROP MANHOLE DETAIL

SCALE: NTS	DATE OF ISSUE: AUGUST 2015
---------------	-------------------------------

REVISED:

DETAIL NUMBER: SS.15

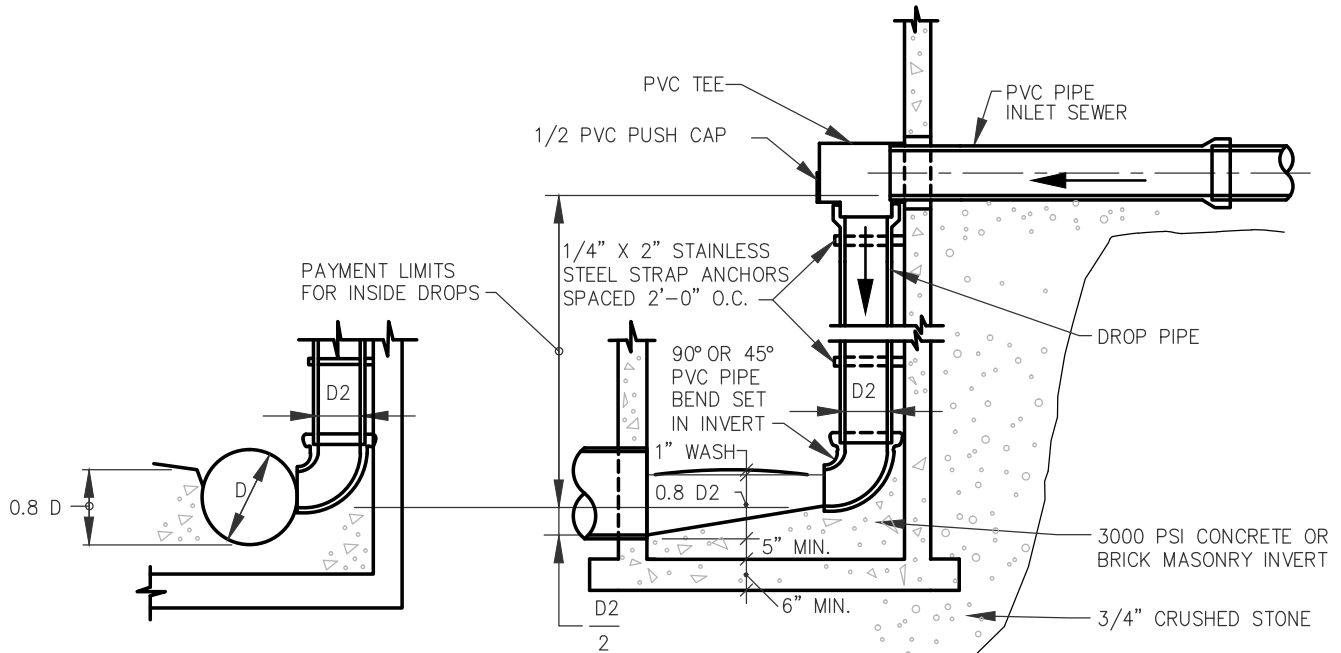

INVERT DETAIL
AT SIDE DROPS

INVERT DETAIL
AT MAIN RUN DROPS

NOTES:

1. INSIDE DROPS ARE ONLY ALLOWED WHEN OUTSIDE DROPS ARE IMPRACTICAL AND ONLY WITH THE PRIOR APPROVAL OF THE DIRECTOR OF ENGINEERING.
2. DROP MANHOLES ARE REQUIRED WHEN THE VERTICAL DROP IS 24" OR GREATER.
3. DROP PIPE AND FITTINGS SHALL BE THE SAME DIAMETER AS THE INCOMING SEWER PIPE.
4. MANHOLE SHALL HAVE SUFFICIENT DIAMETER FOR ENTRY WITH DROP PIPE INSTALLED (5' TYPICAL).



**DEDHAM DPW
DESIGN & CONSTRUCTION STANDARDS**

INSIDE DROPS FOR PVC SEWERS
12-INCH DIAMETER AND SMALLER

SCALE: NTS	DATE OF ISSUE: AUGUST 2015
---------------	-------------------------------

REVISED:

DETAIL NUMBER: SS.16

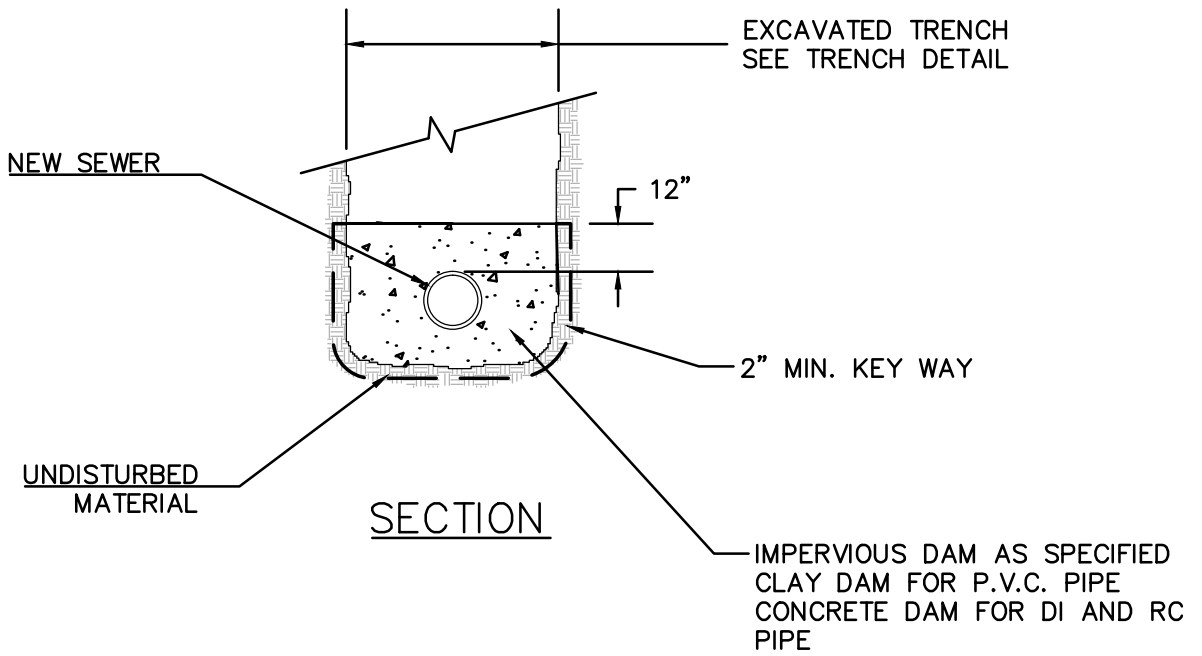
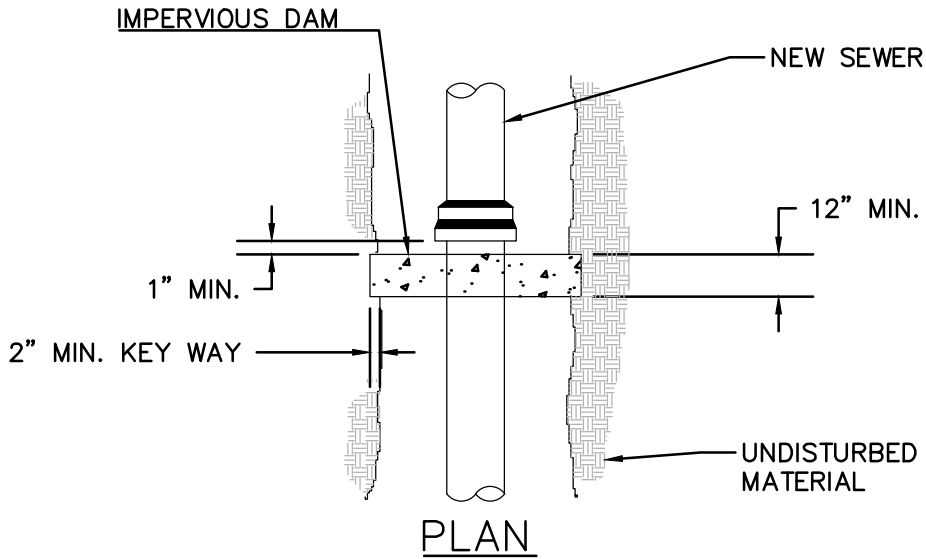

**DEDHAM DPW
DESIGN & CONSTRUCTION STANDARDS**

PIPE TRENCH DAM DETAIL

SCALE: NTS	DATE OF ISSUE: AUGUST 2015
---------------	-------------------------------

REVISED:

DETAIL NUMBER:
SS.17

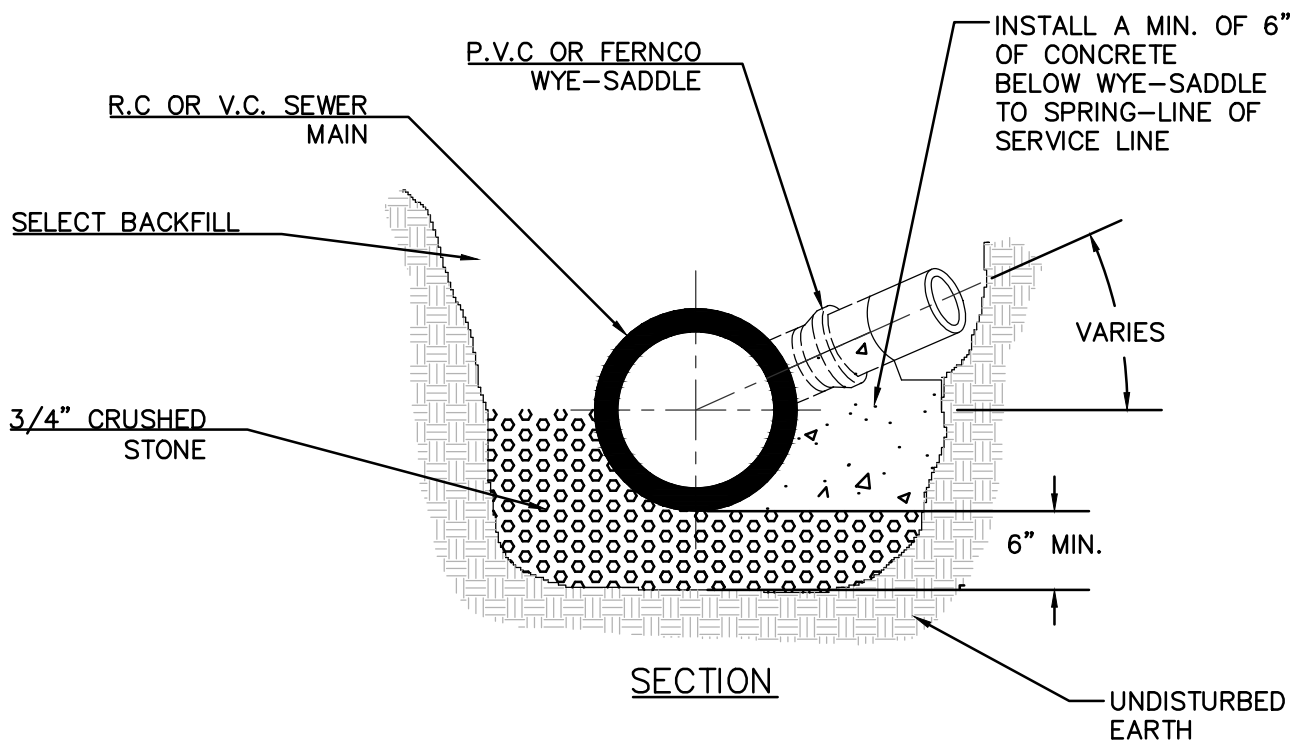
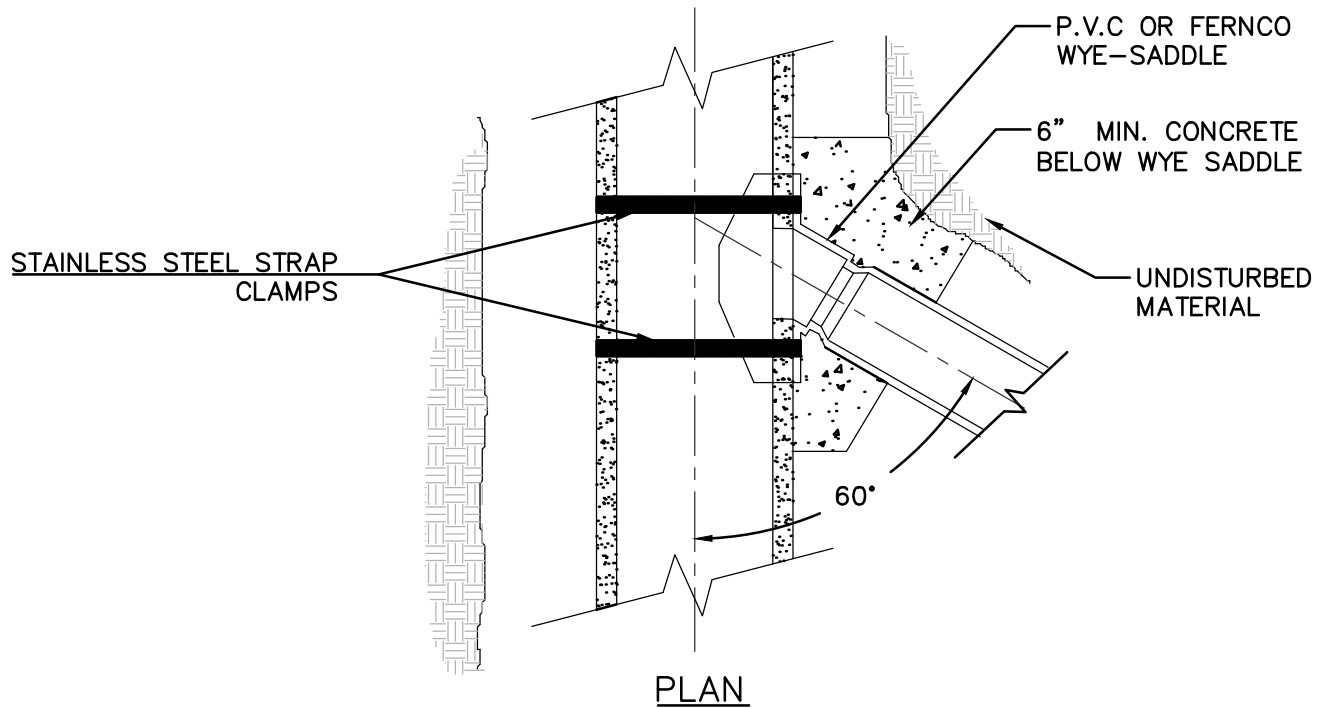

**DEDHAM DPW
DESIGN & CONSTRUCTION STANDARDS**

**WYE-SADDLE DETAIL FOR SERVICE CONNECTION
ON R.C. OR V.C. MAIN**

SCALE: DATE OF ISSUE:
NTS AUGUST 2015

REVISED:

DETAIL NUMBER:
SS.18

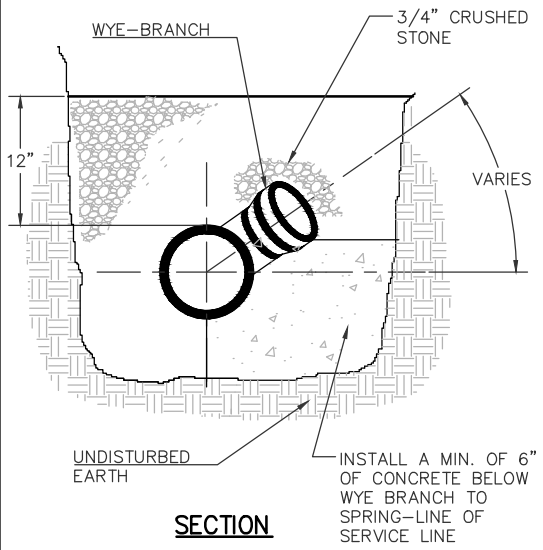

SECTION

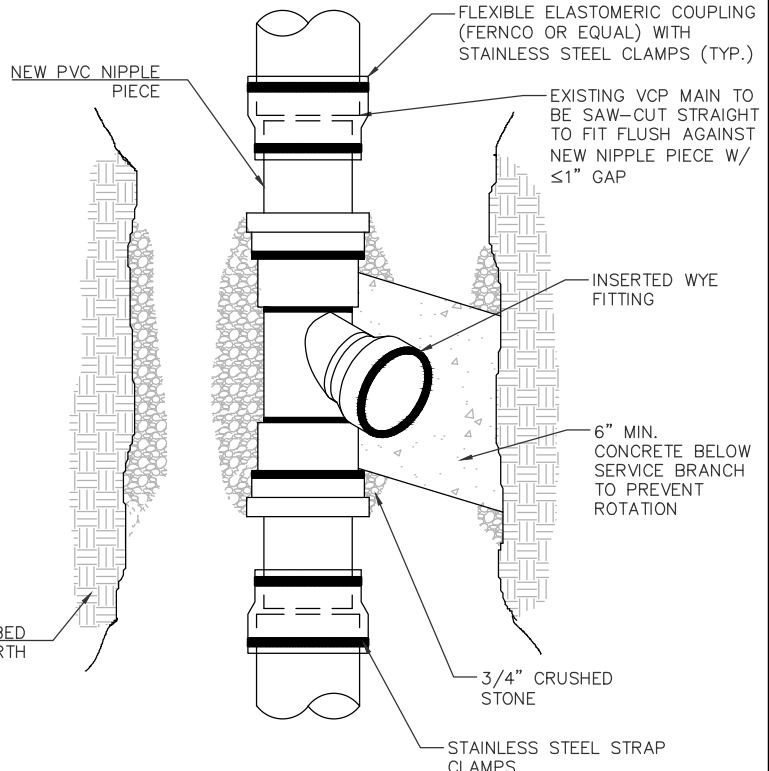

PLAN - VCP MAIN

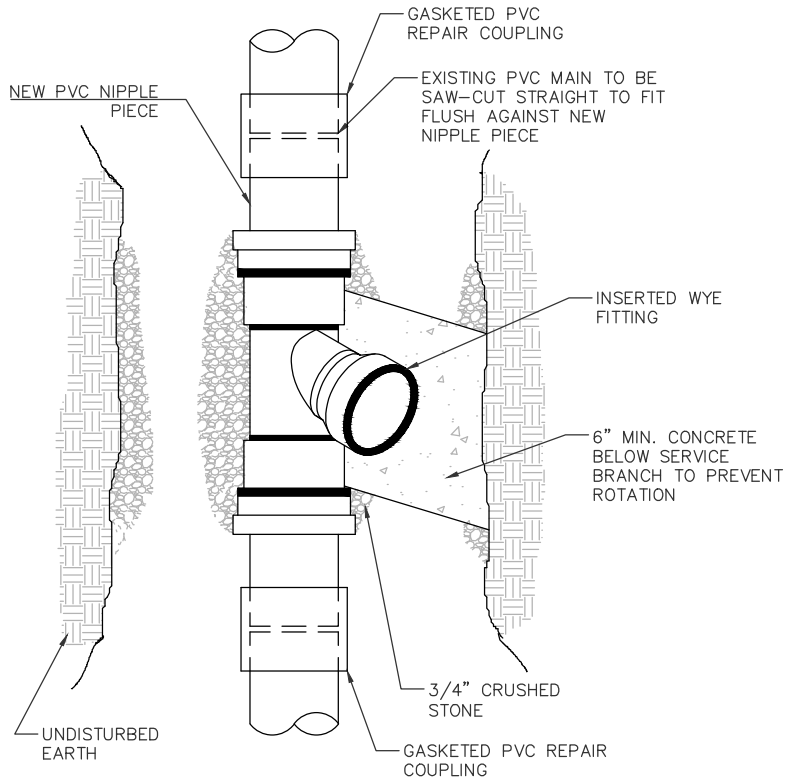

PLAN - PVC MAIN



**DEDHAM DPW
DESIGN & CONSTRUCTION STANDARDS**

P.V.C. WYE INSERTED ON EXISTING MAIN

SCALE: NTS	DATE OF ISSUE: AUGUST 2015
REVISED:	
DETAIL NUMBER: SS.19	

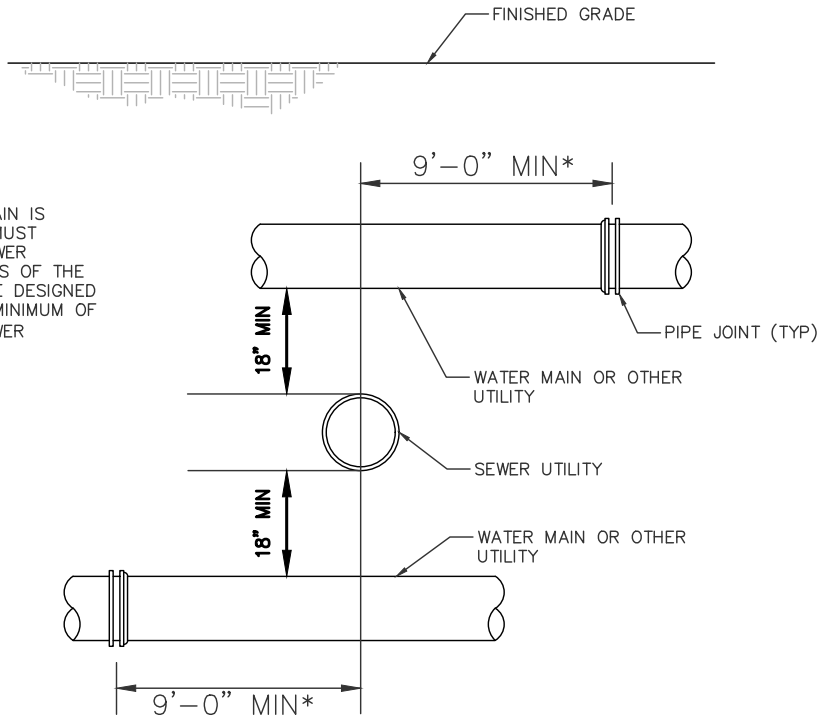

* WHEN A NEW WATER MAIN IS BEING INSTALLED AND MUST CROSS AN EXISTING SEWER UTILITY, THE PIPE JOINTS OF THE WATER MAIN SHOULD BE DESIGNED SO THAT THEY ARE A MINIMUM OF 9' AWAY FROM THE SEWER UTILITY.

NOTES:

1. ANY WATER MAIN OR OTHER UTILITY SHALL NOT BE INSTALLED WITHIN 6" ABOVE OR BELOW AN EXISTING SEWER MAIN OR LATERAL. ALL EFFORTS SHALL BE MADE TO DESIGN UTILITIES WITH THE MINIMUM 18" OF SEPARATION FROM EXISTING SEWER MAINS OR LATERALS.
2. ALL BACKFILLING OPERATIONS FOR SEWER MAINS AND LATERALS SHALL FOLLOW DETAIL NO. SS.02 UNLESS OTHERWISE STATED BELOW.
3. WHERE A WATER MAIN / UTILITY IS TO BE INSTALLED BELOW AN EXISTING VC SEWER MAIN, REGARDLESS OF SEPARATION DISTANCE, THE SEWER MAIN SHALL BE ADEQUATELY SUPPORTED. IF IN THE OPINION OF THE ENGINEER THAT THE SEWER MAIN CANNOT BE ADEQUATELY SUPPORTED, IT SHALL BE EITHER LINED USING APPROVED CIPP METHODS PRIOR TO EXCAVATION BELOW THE SEWER MAIN OR SHALL BE REPLACED WITH PVC C900. IF PVC C900 IS USED, MECHANICAL JOINTS OR AN APPROVED EQUAL THAT ARE WATERTIGHT SHALL BE USED TO FASTEN THE C900 TO THE EXISTING VC SEWER MAIN.
4. WHENEVER A WATER MAIN IS TO BE INSTALLED WITHIN 18" ABOVE AN EXISTING VC SEWER MAIN, IF THE WATER MAIN IS GREATER THAN 12" IN DIAMETER, THE SEWER MAIN SHALL BE LINED USING APPROVED CIPP METHODS PRIOR TO THE INSTALLATION OF THE WATER UTILITY.
5. WHERE A WATER MAIN IS TO BE INSTALLED BELOW AN EXISTING VC SEWER LATERAL, REGARDLESS OF SEPARATION DISTANCE, THE SEWER LATERAL SHALL BE EITHER ENCASED IN A MINIMUM OF 6" OF CONCRETE FOR A MINIMUM OF 10' ON EACH SIDE OF THE CROSSING, OR THE SEWER LATERAL SHALL BE REMOVED AND REPLACED WITH PVC SDR 35 PIPE FOR THE FULL WIDTH OF THE TRENCH. FERNCO COUPLINGS, OR APPROVED EQUALS THAT ARE WATERTIGHT SHALL BE USED TO CONNECT THE PVC PIPE TO THE EXISTING VC SEWER LATERAL.
6. WHENEVER A WATER MAIN / UTILITY IS TO BE INSTALLED WITHIN 18" ABOVE AN EXISTING VC SEWER LATERAL, IF THE WATER MAIN / UTILITY IS GREATER THAN 12" DIAMETER, THE SEWER LATERAL SHALL BE EITHER REMOVED AND REPLACED WITH PVC C900 OR DI PIPE FOR THE FULL WIDTH OF THE TRENCH OR THE SEWER LATERAL SHALL BE LINED USING APPROVED CIPP METHODS FOR A MINIMUM DISTANCE OF 10' ON EACH SIDE OF THE CROSSING.
7. WHERE A WATER MAIN / UTILITY IS INSTALLED BELOW AN EXISTING SEWER LATERAL, IF THE LATERAL IS COMPRISED OF CI, DI OR PVC MATERIAL, THE LATERAL CAN REMAIN IN PLACE PROVIDED IT IS ADEQUATELY SUPPORTED DURING EARTHWORK ACTIVITIES.



**DEDHAM DPW
DESIGN & CONSTRUCTION STANDARDS**

TYPICAL UTILITY CROSSINGS

SCALE: NTS	DATE OF ISSUE: AUGUST 2015
---------------	-------------------------------

REVISED: 7/26/2018

DETAIL NUMBER: SS.20

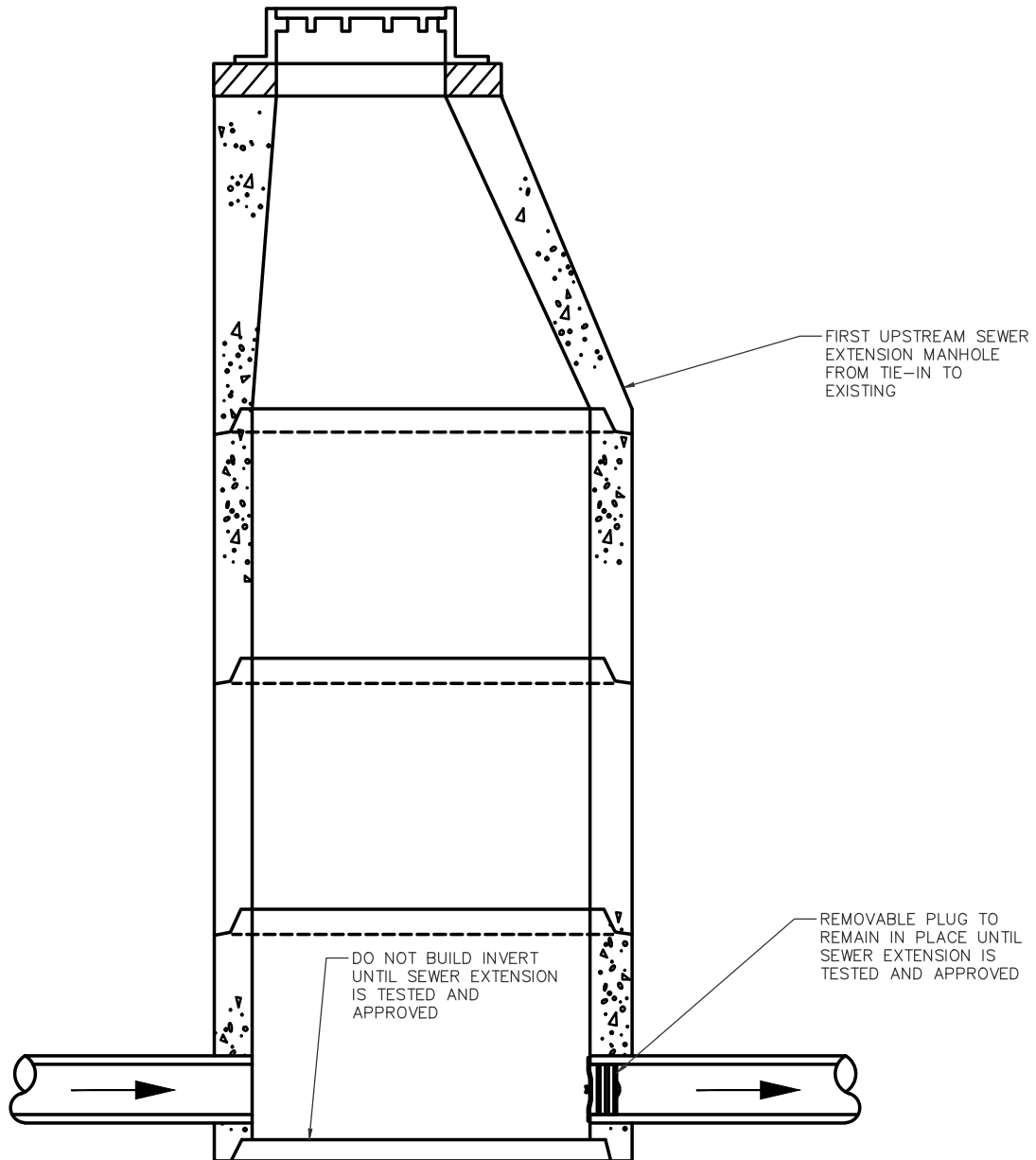

**DEDHAM DPW
DESIGN & CONSTRUCTION STANDARDS**

SANITARY SEWER PROTECTION DURING
SEWER EXTENSION CONSTRUCTION

SCALE: NTS	DATE OF ISSUE: AUGUST 2015
REVISED:	
DETAIL NUMBER: SS.21	

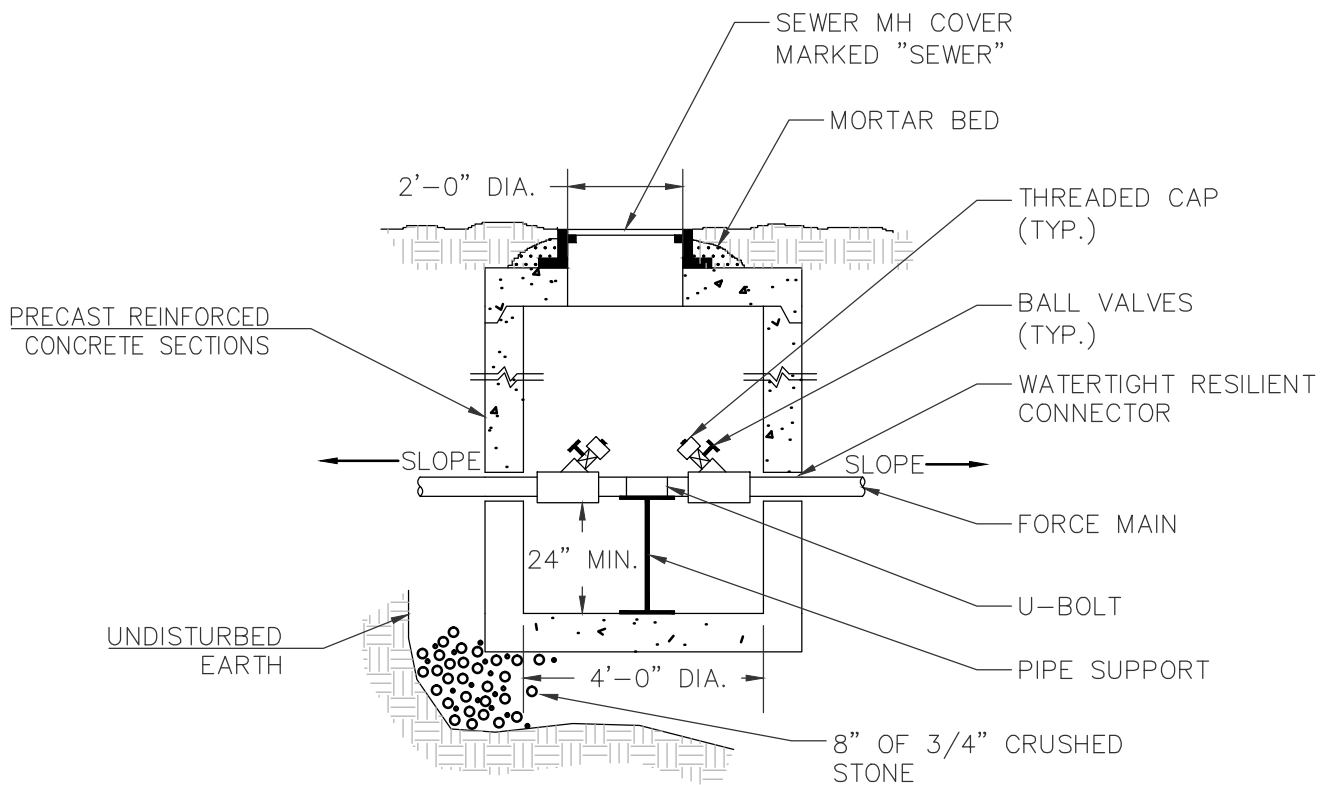

SECTION

NOTES:

1. PROVIDE MANHOLE STEPS 1'-0" O.C.
2. CONTRACTOR SHALL CONFIRM ELEVATION AND ALIGNMENT OF PROPOSED FORCE MAIN AND GROUND SURFACE AT EACH MANHOLE PRIOR TO ORDERING SECTION.
3. ADJUST FRAME TO GRADE WITH A MINIMUM OF TWO COURSES OF BRICK MASONRY OR REINFORCED CONCRETE GRADE RINGS (NOT SHOWN).
4. ALL EXTERIOR SURFACES OF GRADE ADJUSTMENT COURSES SHALL BE COVERED WITH 1/4" TO 3/8" MASONRY CEMENT PLASTER.



**DEDHAM DPW
DESIGN & CONSTRUCTION STANDARDS**

FORCE MAIN CLEANOUT MANHOLE DETAIL

SCALE: NTS	DATE OF ISSUE: AUGUST 2015
---------------	-------------------------------

REVISED:

DETAIL NUMBER: SS.22

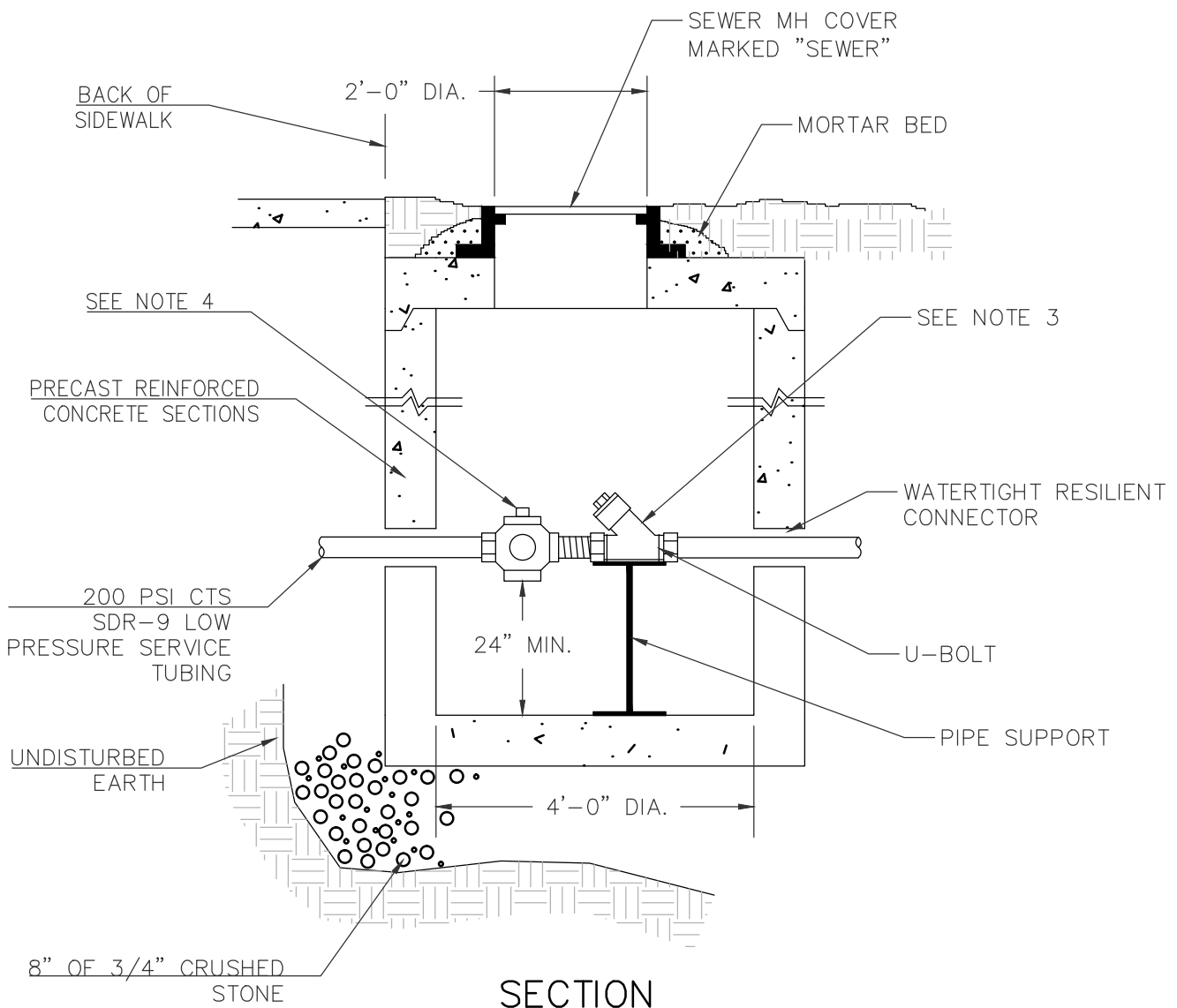

SECTION

NOTES:

1. PROVIDE MANHOLE STEPS 1'-0" O.C.
2. CONTRACTOR SHALL CONFIRM ELEVATION AND ALIGNMENT OF PROPOSED LOW PRESSURE SERVICE(S) AND GROUND SURFACE AT EACH MANHOLE PRIOR TO ORDERING SECTION.
3. SINKING BALL CHECK VALVE - FEMALE IPS X IPS (FLOMATIC MODEL 208, PART NO. 2142, OR EQUAL) W/ MUELLER 110 (OR EQUAL) COMPRESSION CONNECTION.
4. SHUT-OFF VALVE - IPT MUELLER 300 BALL CURB VALVE B-25122, OR EQUAL W/ MUELLER 110 (OR EQUAL) COMPRESSION CONNECTION.
5. ADJUST FRAME TO GRADE WITH A MINIMUM OF TWO COURSES OF BRICK MASONRY OR REINFORCED CONCRETE GRADE RINGS (NOT SHOWN).
6. ALL EXTERIOR SURFACES OF GRADE ADJUSTMENT COURSES SHALL BE COVERED WITH 1/4" TO 3/8" MASONRY CEMENT PLASTER.



**DEDHAM DPW
DESIGN & CONSTRUCTION STANDARDS**

**LOW PRESSURE SEWER SERVICE
VALVE BOX**

SCALE: NTS	DATE OF ISSUE: AUGUST 2015
---------------	-------------------------------

REVISED:

DETAIL NUMBER:
SS.23

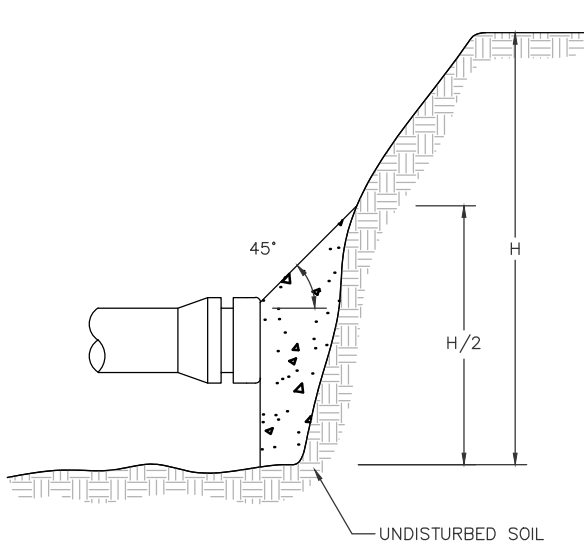

PLUG / DEAD END - ELEVATION

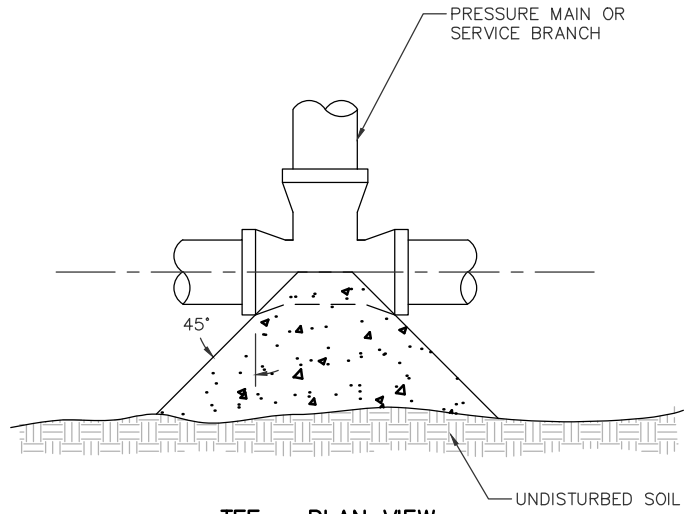

TEE - PLAN VIEW

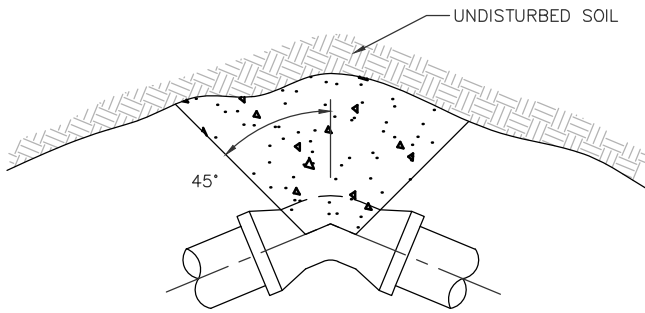

ELBOW - PLAN VIEW

NOTES:

1. THRUST BLOCKS SHALL BE Poured AGAINST UNDISTURBED SOILS USING FORMS AND 3,000 PSI CONCRETE.
2. CONCRETE SHALL NOT OBSTRUCT ANY BOLTS OR FLANGES.
3. THRUST AND BEARING AREA CALCULATIONS PERFORMED BY A PROFESSION ENGINEER LICENSED IN THE STATE OF MASSACHUSETTS MAY BE REQUIRED AT THE DISCRETION OF THE DIRECTOR OF ENGINEERING.



**DEDHAM DPW
DESIGN & CONSTRUCTION STANDARDS**

THRUST BLOCKS

SCALE: NTS	DATE OF ISSUE: AUGUST 2015
---------------	-------------------------------

REVISED:

DETAIL NUMBER: SS.24

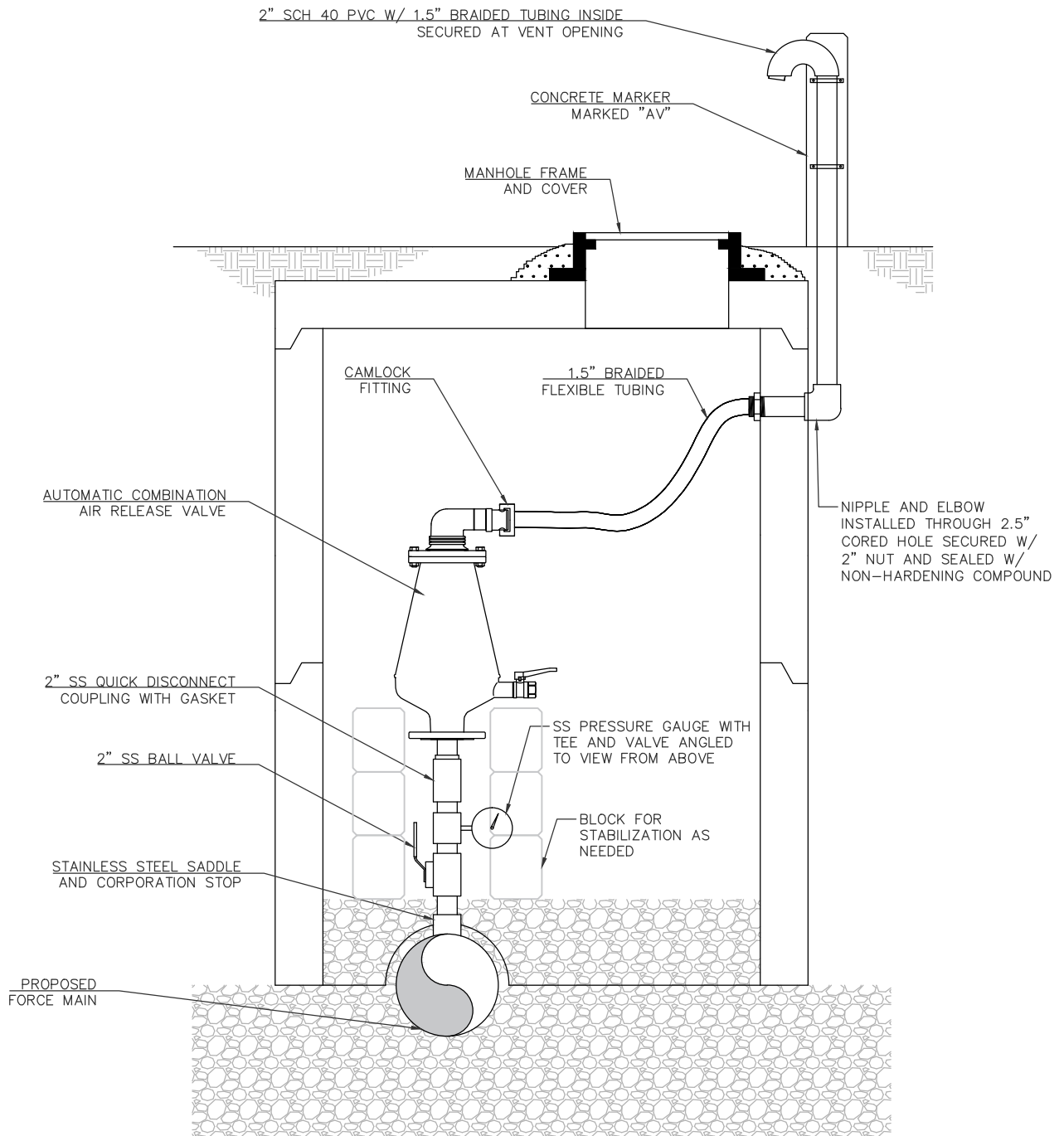

NOTES:

1. FORCE MAIN PROFILE AND ARV LOCATION TO BE ADJUSTED SUCH THAT ARV IS AT HIGH POINT WITH SUFFICIENT DEPTH FOR INSTALLATION AND TO PREVENT FREEZING.
3. ADJUST FRAME TO GRADE WITH A MINIMUM OF TWO COURSES OF BRICK MASONRY OR REINFORCED CONCRETE GRADE RINGS (NOT SHOWN).
4. ALL EXTERIOR SURFACES OF GRADE ADJUSTMENT COURSES SHALL BE COVERED WITH 1/4" TO 3/8" MASONRY CEMENT PLASTER.



**DEDHAM DPW
DESIGN & CONSTRUCTION STANDARDS**

COMBINATION AIR RELEASE VALVE

SCALE: NTS	DATE OF ISSUE: AUGUST 2015
---------------	-------------------------------

REVISED:

DETAIL NUMBER: SS.25

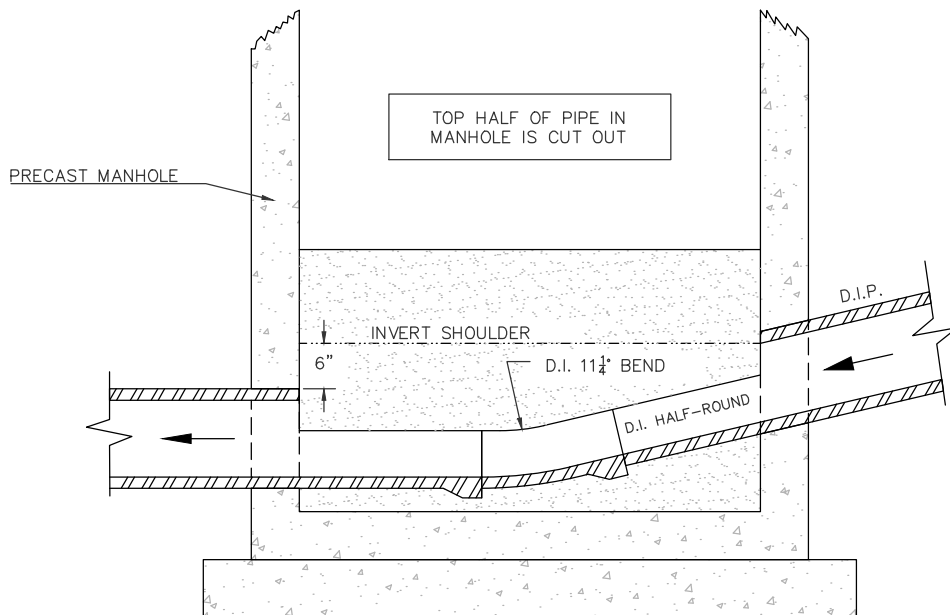
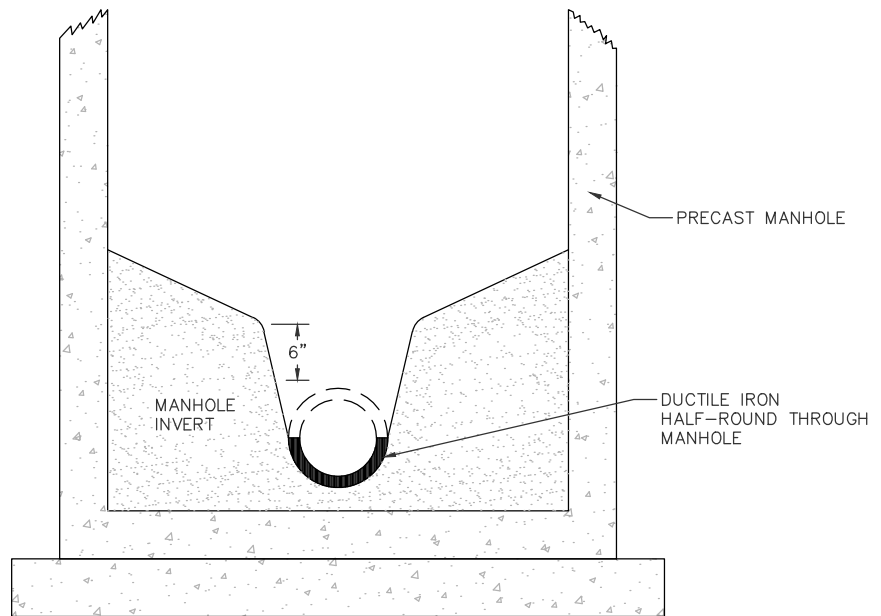

NOTES:

1. NO HORIZONTAL ALIGNMENT CHANGE CAN BE MADE WITHIN THIS MANHOLE TYPE. USE ON GRADES OF 10% OR GREATER.
2. EACH JOINT OF PIPE BETWEEN HIGH VELOCITY MANHOLE & MANHOLE UPGRADE SHALL HAVE A TRENCH DAM (SS.17).



**DEDHAM DPW
DESIGN & CONSTRUCTION STANDARDS**

HIGH VELOCITY MANHOLE INVERT

SCALE: NTS	DATE OF ISSUE: AUGUST 2015
REVISED:	
DETAIL NUMBER: SS.26	

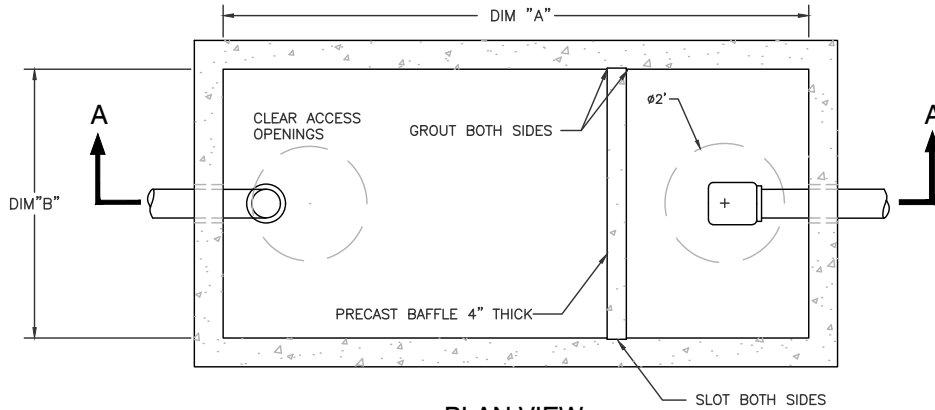

PLAN VIEW

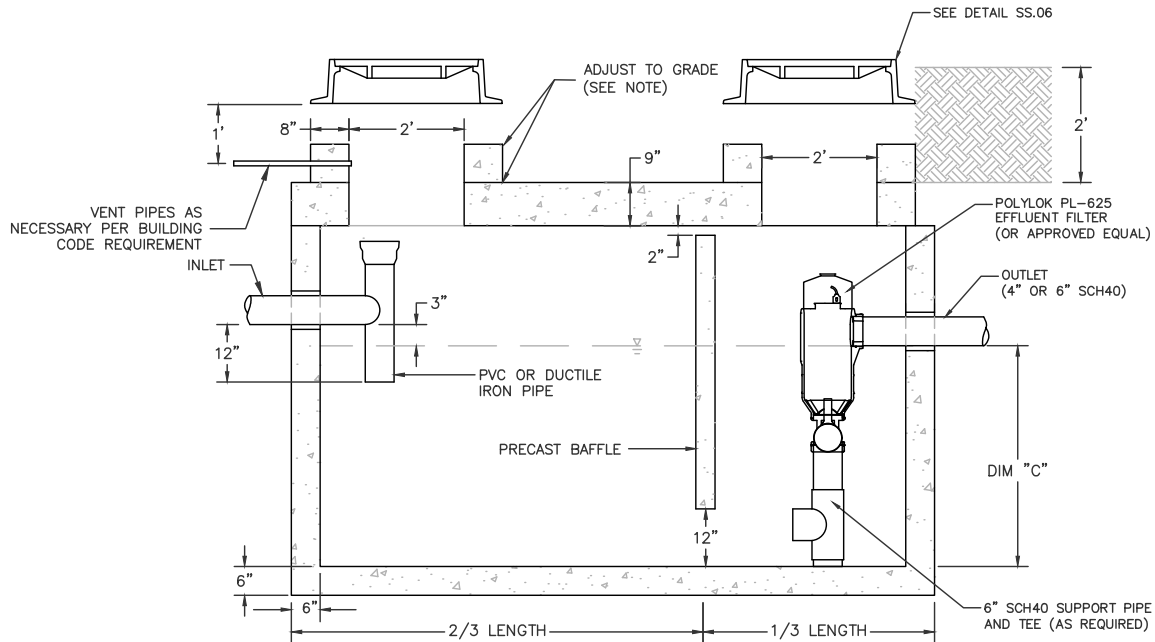

SECTION A-A

SIZING CHART			
GALLON CAPACITY	DIM "A"	DIM "B"	DIM "C"
1500 (MIN.)	120"	60"	48"
1750	120"	60"	58"
2000	144"	68"	48"
2500	144"	72"	56"
2750	144"	72"	62"
3000	168"	84"	50"
4000	168"	84"	66"
5000	216"	96"	56"
6000	216"	96"	68"

NOTES:

1. CONCRETE: 28 DAY F'c= 4500 psi
2. REBAR: ASTM A615 GRADE 60
3. MESH: ASTM A-185 GRADE 65
4. DESIGN: AC1318-83 BUILDING CODE
ASTM C-857 MINIMUM STRUCTURAL DESIGN
LOADING FOR UNDERGROUND PRECAST
CONCRETE UTILITY STRUCTURES
5. LOADS: H-20 LOADING
6. FILL w/ CLEAN WATER PRIOR TO START UP OF SYSTEM
7. CONTRACTOR TO SUPPLY AND INSTALL ALL PIPING AND
SANITARY TEES
8. GRAY WATER ONLY, BLACK WATER SHALL BE CARRIED BY
SEPARATE SEWER
9. TRAP SIZE WILL BE BASED ON 15 GPD PER SEAT
10. LARGER SIZES MAY BE REQUIRED AS PER REVIEW OF FACILITY
11. WHERE COVER OVER GREASE TRAP EXCEEDS 2', 4' DIAMETER
PRECAST CONE SECTIONS SHALL BE USED.
12. TOP, WALL, AND BASE THICKNESS MAY BE ADJUSTED AS
NEEDED BY PRECASTER TO MEET H-20 LOADING.



**DEDHAM DPW
DESIGN & CONSTRUCTION STANDARDS**

STANDARD GREASE TRAP

SCALE: DATE OF ISSUE:
NTS AUGUST 2015

REVISED:
7/26/2018

DETAIL NUMBER:
SS.27

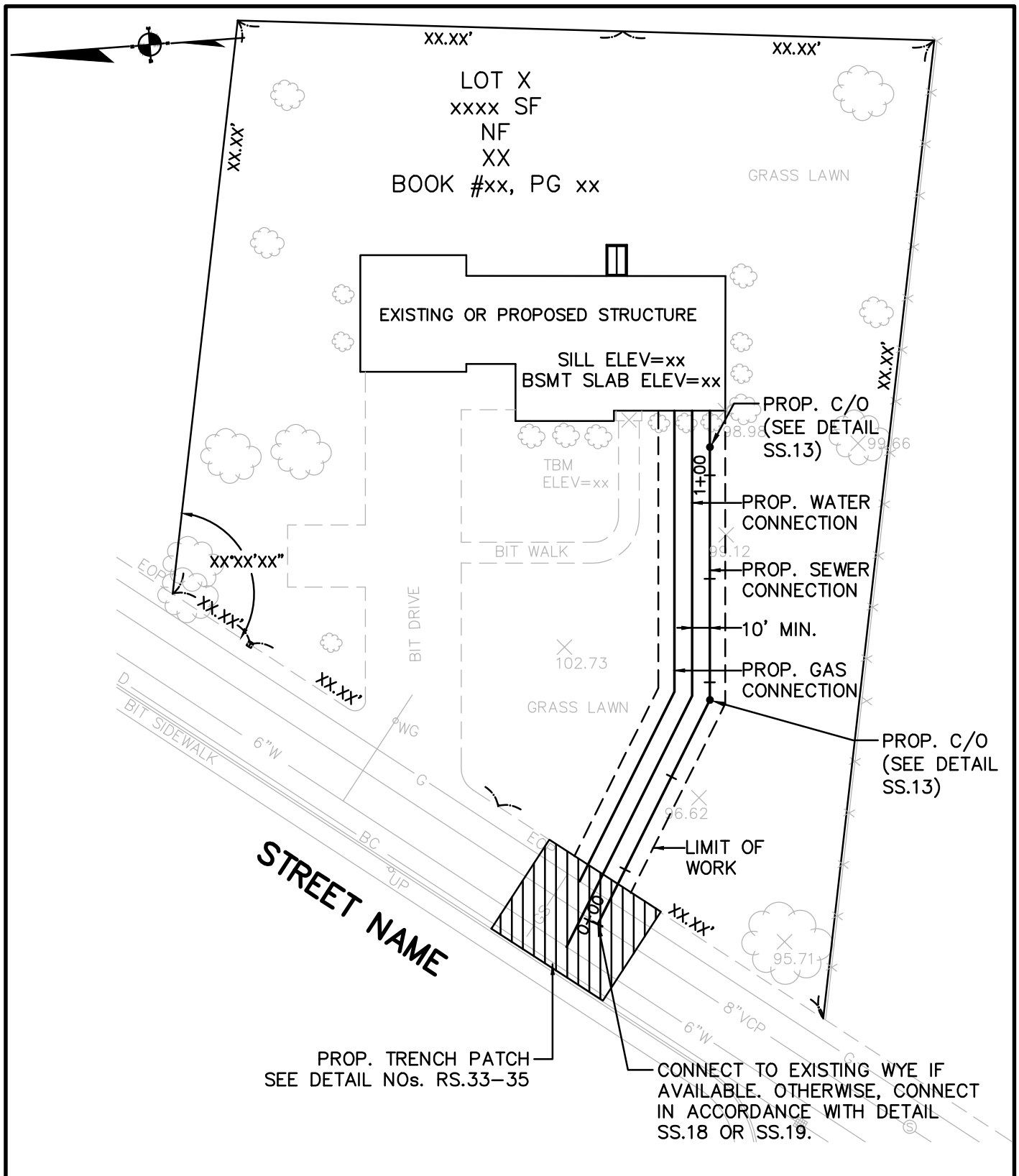

**DEDHAM DPW
DESIGN & CONSTRUCTION STANDARDS**

TYPICAL SEWER PLAN

SCALE: NTS	DATE OF ISSUE: AUGUST 2015
REVISED:	
DETAIL NUMBER: SS.28	

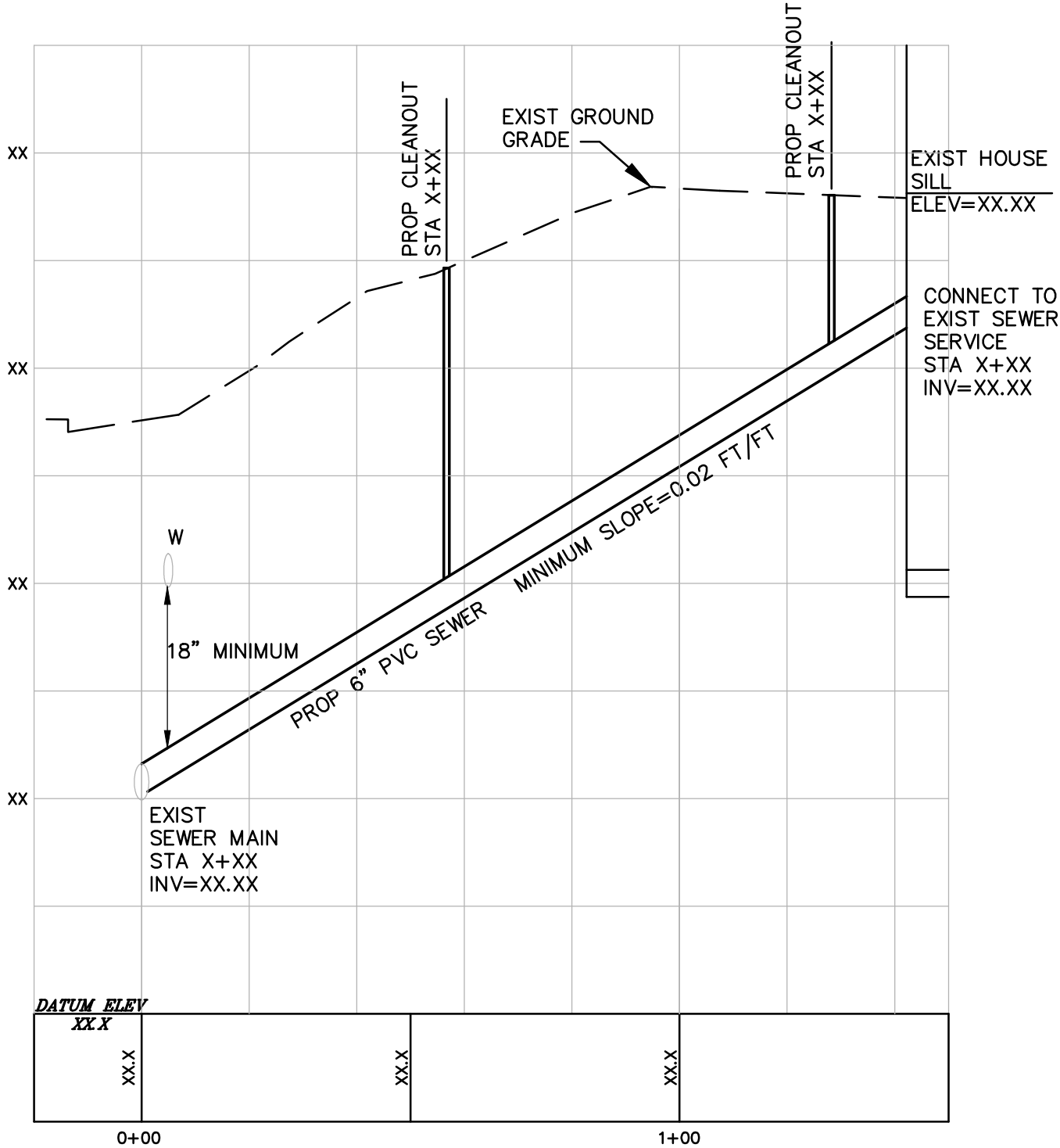

DATUM ELEV			
XX.X			
XX.X		XX.X	XX.X
0+00			1+00



**DEDHAM DPW
DESIGN & CONSTRUCTION STANDARDS**

TYPICAL SEWER PROFILE

SCALE: NTS	DATE OF ISSUE: AUGUST 2015
REVISED:	
DETAIL NUMBER: SS.29	